

TARGET ISSUE

usability in electronic environments

Psychology

Journal Vol(1)-1. Summer 2002

...Make yourself at home

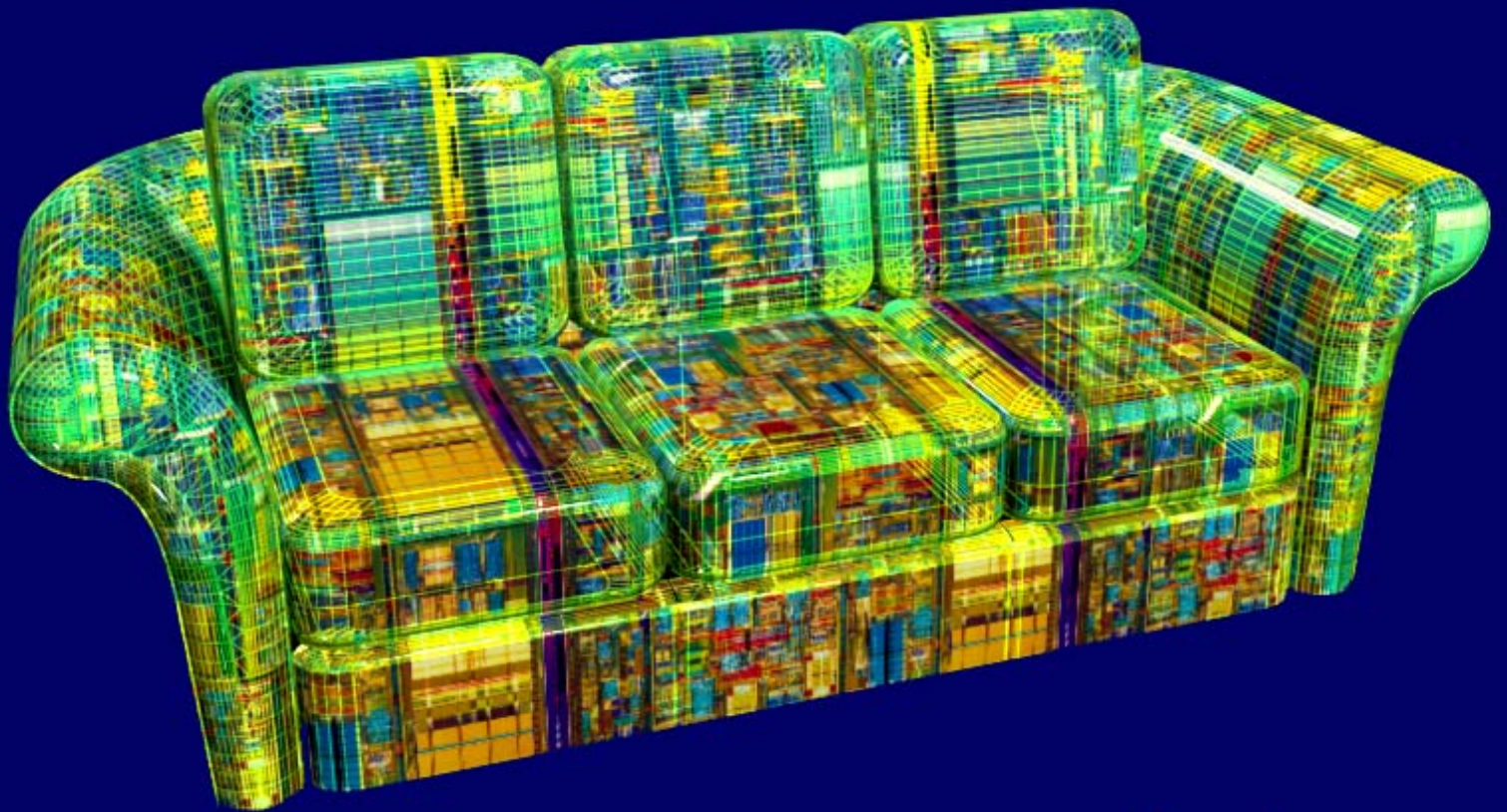

www.psychology.org

Table of Contents

Table of Contents.....pag. 3

TARGET ISSUE: Usability in Electronic Environment

Editorial Prefacepag. 4

Breakdown analysis.....pag. 5
A. Spagnolli, L. Gamberini, D. Gasparini.

Web Usability Revisited: A Situated Approach.....pag.18
G. Riva.

OTHER CONTENTS:

Educational interaction in distance learning.pag.28
M. Casarotti, L. Filippini, L. Pieti, R. Sartori.

Ethical aspects on children uses of IT.pag.39
C. Ruggeroni.

Virtual Unreality of Videogames.pag.57
P. Guardini.

Editorial Preface

Time has passed since the idea first crossed our minds of a periodic publication devoted to a theme fascinating us to the point of obsession: the strict connection between humans and technologies. Enjoyable from so many different perspectives - practical, artistic, philosophical-, this theme is acquiring more and more supporters now, gradually dissolving clear-cut disciplinary distinctions that separate people from their technical artifacts and showing its strong conceptual and practical assets.

Simple in its basic claim but subtle in its actual deployment, this perspective calls for complex, careful investigative efforts and pays back with a richer, closer grasp of the phenomena it is applied to. In the process of its realization, the original idea of a newsletter has been replaced by that of a website with an included periodical publication, where a more variegated set of activities could be displayed and which could better support our expanding community, whose core is constituted of people knowing each other for having worked together at times, but seeks new contributors relentlessly.

The point of the journal is in fact to make visible new, original work and, seizing on the advantages of an electronic publication, to attract fresh yet circumstantiated ruminations from young authors on whatever format they prefer. The journal intends to facilitate the exploration of its general theme by proposing a specific topic each issue; for the first issue we have selected the topic of 'usability' since it is well representative of how technologies are intertwined with people

using them and are affected in their very design and functioning by such interdependence.

Usability is a widely acknowledged concern in the engineering community and has triggered close cooperation with other disciplinary fields. Two papers address this issue; Spagnoli, Gamberini and Gasparini describe a procedure ('breakdown analysis') step-by-step for the usability evaluation of virtual environments, implementing those action-based theories which are currently receiving such a warm appreciation in the field of Human-Computer Interaction. A similar theoretical approach is supported by Giuseppe Riva, whose paper offers a comprehensive framework to handle the issue of web usability and organize the confusing plethora of recommendations available in the literature.

Casarotti et al. reviewed various distance learning solutions too see how performance is effected by the degree of interaction users are allowed.

There is another contribution on usability, written by Pietro Guardini who interrogates on the extent to which a successful videogame can be said 'realistic' and guides the reader thorough a detailed series of examples to illustrate the tricks through which players' expectations are indulged.

We hope you will find this first issue satisfying and the topic so intriguing in itself to send your own contribution to the journal or to any other section of the web site.

The Editors in Chief

Situated Breakdown Analysis for the Evaluation of a Virtual Environment

Spagnolli Anna[✦], Gamberini Luciano, Gasparini Daniele

Department of General Psychology
University of Padova, Italy

ABSTRACT

It is a widely-supported tenet in human-computer interaction that the meaningful unit of analysis is not the technical device alone, but the technical device together with the person interacting with it; the reason is that what is a relevant property of a technology is only understandable with respect to the specific goals and resources activated during its usage. This basic reflection should also inspire the procedure followed to evaluate the usability of a technology, namely its efficiency and satisfaction for a specific class of users. The topic of this paper is precisely to describe a method developed in compliance with this observation and aimed at evaluating the usability of virtual environments. Two main requirements were set forth: first, the method should take the strong connection between humans and technology as its building block, by linking a property of the virtual environment to a particular use that makes that property relevant. To this goal, action has been placed at the center of the analysis; the functional properties of the VE are then observed in the general economy of users' interaction with the technology and the whole ensemble is the appropriate object of evaluation. Such 'action-based' approach (Gamberini, Spagnolli, 2002) is reminiscent of the Situated Action theory (Suchman, 1987) and Activity Theory (Nardi, 1996); the former proposes a detailed analysis of the sequential interaction with the technology and provides a rich examination of the structure given to it by the users. The latter focuses more on specific phenomena, such as contradictions and breakdowns, identified by the evaluators; it allows to profit from data poor in comments and verbalizations, and to analyze the interaction with the technology from a structural and organizational level. As a second requisite for the method, we wanted it to benefit from the advantages of both approaches; thus we decided to concentrate on the breakdowns occurring during users' interaction with the VE but to study these episodes from a situated point of view. In our definition, breakdowns reveal an inappropriate interpretation of the possibilities for action offered by the virtual environment and are to be analyzed in their sequential, contextual unfolding. This version of breakdown analysis highlights the spontaneous, subjective problems in the use of a technology and connects them to specific aspects of users' action. It renews the ergonomic tradition of error studies (Reason, 1990; Rasmussen, 1980) with an ethnographic contamination, that pays attention to users' contextualized practices. It also suits the kind of data the interaction with a virtual environment is mostly made of, namely bodily action in a three-dimensional space. Few methods with these characteristics have been employed so far to analyze the interaction with the VE. After a brief introduction, the paper will describe the basics of this approach and illustrate them with instances from the evaluation of a virtual library.

Keywords: *presence, virtual environments, interaction analysis, VE usability.*

Received 22 June 2002; accepted 25 June 2002.

[✦] Corresponding Author:

Anna Spagnolli, Dipartimento di Psicologia Generale,
Università degli Studi di Padova, via Venezia 8, 35131 Padova, Italy.
Tel: +39-049-8276644
Fax: +39-049-8276600
E-mail: anna.spagnolli@unipd.it

1. Evaluating a virtual environment in use: situated, action -based approach.

The structure and features of a virtual environment (VE), like the structure and features of any technical artifact, are much more plastic than we may think. Let alone inexperience or exceptional misunderstandings, there is an inescapable process that shapes an artifact according to the practices of use, so that the artifact in the context of use can differ substantially from how it appears in its engineering description. This description offers but one perspective on the artifact, from the viewpoint of the designers and for the benefit of their practical concerns. In fact, each class of people that will get in touch with the technology comes up with own pictures of the technical artifact, based on the actions performed with it (Law, 1992; Carroll et al. 1994, Kling, 1980; 1992; Button, 1993; Mantovani, 1996; Mantovani, Spagnoli, 2001; Lea, 1992; Zucchermaglio et al. 1995; Greenbaum, Kyng, 1991; Ciborra, Lanzara, 1990): the properties of a car will differ substantially depending on whether one wants to mend it, advertise it, buy it, park it. Those interpretations are unpredictable, since nobody can figure in advance the vast variety of settings in which a technological product will be eventually placed and what they will look like. For this reason, before releasing a technical artifact in the market and sometimes even periodically throughout its life, it is highly recommended to test the users' interpretations (Gamberini, Valentini, 2001).

In the case of virtual environments, this recommendation is still overlooked. Human factors are usually considered very early in the design process, except for the measurement of the sense of presence conveyed by the simulation, which is assessed at the end, but usually covers only perceptual and sensory-motor processes (Wann, Mon-Williams, 1996; Stanney et al., 1998; Steuer, 1992). What is largely missing is a systematic study of the process of interaction with the VE, to have a comprehensive appreciation of how users interpret the functioning of the system. We can look for inspiration in the parent field of Human Computer Interaction, where we can find two particularly interesting frameworks conceptualizing the interaction with a technology, namely the 'situated' and the action-oriented frameworks. Taken together, those perspectives see users' interpretation as an embodied, practical phenomenon, instead of a mental, abstract one (activity theory: Engeström et al., 1999; Nardi, 1996; phenomenology: Ihde, 2002), which takes shape in the contingent, sequential unfolding of the interaction (ethnography: Button, 1993; Suchman, 1987; Hutchins, 1995 and discourse/interaction analysis: Luff et al., 1990; Jordan, Henderson, 1995; Engeström, Middleton, 1996). They look especially useful in case of virtual environments, where interaction is basically action in a three-dimensional space performed with material and

virtual resources. We then adopted this perspective and evaluate how the properties of the VE figure in users' situated action with the VE.

2. What to look for: breakdowns

A good rationale to evaluate the usability of a technology is to start from those events that reveal problematic, in other words, where user's interpretation of the artifact results inadequate.

To evaluators, problems and errors have always proved an insightful locus of analysis (Reason, 1990; Engeström, 1996; Carroll, 1993; Flanagan, 1954). The selection of problematic episodes can be accomplished in two ways, 'normative' or 'open'. In the former, the evaluator refers to a pre-established list of expected results; interactions are then inspected to single out the circumstances under which the actual interaction and the expectations are mismatched. The 'open' approach, instead, is more explorative. The procedure consists again of collecting and analyzing fragments of interaction in which some problems occur; only, this time the selection criterion is not the designer's, but the users', for the identification of a problem depends on some signals coming from the interaction itself. This latter approach applies when one prefers to pay more attention to the structure of the interaction in order to decide whether a passage is problematic or not, or when no specification is provided of the expected results, either because evaluators are interested in unexpected events, or because designers are not available to provide the list of expectations altogether. This approach is even more valuable if it can work in absence of verbal cues, for this would help in all cases in which users react to problems by quitting talk and concentrating on the difficulty, instead of asking questions and making comments.

The criterion we applied to collect problematic episodes without relying on verbal cues *only* and on designers' expectations was to look for spontaneous breakdowns. They are crisis in the interpretation of the situation, that force actors to suspend the current activity and mend the interpretative flaw (Winograd, Flores, 1986). From a situated, action-based perspective, in addition, breakdowns are not mental events, located in the cognitive processes of the user, but episodes involving the action of the user in the environment. *The actor is forced to abandon the environment-action-person configuration adopted up to that moment and mobilize resources to obtain a more effective one* [1].

Procedurally, that means that:

- the observational focus is on the user's projected course of action (a certain actor-environment-action configuration), and its expected evolution;
- when a suspension or interruption of the course of action occurs, this is taken as an index of a breakdown episode, along with other concurrent evidences such as unexpected outcomes, verbal cues, gestures, pauses.

For example:

1. PROJECTED COURSE OF ACTION. The user is approaching a door in the virtual environment (Figure 1); the fact that he is moving towards the door, that he has been suggested to explore the virtual library and its features and he says 'let's go out, let's see if we can exit' suggests that the projected action is an attempt at opening the door.



Figure 1

2. BREAKDOWN. The course of action does not go through; the usual strategy to interact with an object (namely clicking on a dedicated button of the joystick) does not produce any results. The analyst registers the frame at which this interruption occurs and includes the following attempts at opening the door as part of the breakdown episode, which stops when the course of action leaves room to a new one. In this specific example, the episode stops after a series of attempts, when the user states that the door would not open and goes on with the navigation.

2 Tricky cases.

2.1 Complex breakdowns.

As we explained in the previous paragraph, each breakdown refers to one course of action, namely to a certain relationship person-environment-action, which tends recognizably to some consequence [1]. There are particularly tricky cases in which multiple connected problems occur. Here, a precise reference to the course of action is useful to establish when a breakdown episode is over and decide if a problem belongs to the same episode or ushers a new one. For example, when a new course of action intervenes before the previous one is through (either resolved or abandoned), like when the evaluator tries to help and a misunderstanding occurs, inserting a new breakdown into the previous one. For example, see the following episode (see the appendix for transcription symbols):

- 1 P: *((he stops in front of the windows of an office, clicks a button of the joystick several times; nothing happens; so he goes on to his left))*
- 2 R: that one (.) is the window,
- 3 the other one is the door.
- 4 P: pardon:?

Here the breakdown episode is re-opened by the researcher who refers to the just abandoned course of action (the attempt at opening a door) and suggests a solution: it is possible to enter the room, just the participant was mistaking the window-wall for the door. While addressing the breakdown with this suggestion, another breakdown occurs, this time communicative, since the participant cannot hear what the researcher is saying and initiates a 'repair' (in conversation analysis terms) by asking 'pardon?' In this case we have multiple breakdowns because we have different connected courses of action. Otherwise, we are assisting to a series of problems within the same breakdown episode, like in the remaining of the sequence reported above:

- 5 *((stopping and touching the headphones; a door is in his view))*

- 6 R: the other one is the door if you want to enter there.
7 (go) more towards your right,
8 P: [((he goes towards another door))
9 R: [(.4) no the o-
10 P: ((he stops; he's in front of the second door))
11 R: not that one.
12 P: ((he turns to his right; the first door is in his view))
13 [thi:s one.

Here there are multiple attempts at conveying a helping instruction. Each attempt and the corresponding failure is not a breakdown on its own, but part of a series of attempts in the same episode, since they all try to deliver the same course of action, namely entering the room.

2.2 Verbalizations.

Videotapes do not speak for themselves, but are interpreted by the evaluator (Suchman, 1995; Shotter, 1983; Biggs, 1983), whose work will be facilitated by familiarity with the context (by interacting several times with the VE, being present during the videorecording and being cognizant of the goals of the virtual environment and the interaction) and by eliciting some verbalization from the participant. How should those verbalizations be considered? Discourse analysis reminds us that they shouldn't be taken literally, as neutral descriptions: words do not label actions, they are actions themselves, either concurrent or divergent with their non verbal actions. When the participant talks to the evaluator about the ongoing breakdown, then, she is not describing it but articulating it, making sense of what is happening at the interlocutors' benefit (Smagorinski, 1998). In the following fragment, the participant turns to the right, where a wooden board appears in front of her and she retracts in a sudden, effective movement that reverses her previous turn. Her exclamation is not simply a spontaneous expression of surprise; it is prolonged from an 'o' into an 'o:god' which extends until her retraction is over and conveys a strained attitude.

3 Procedure

The breakdown analysis consists in two basic steps: identifying and collecting breakdown episodes and then analyzing their structure and development. The first steps has been dealt with in the previous paragraph. Once the episodes have been collected, the evaluator wants to *analyze the structure of the course of action (the actor-environmental affordances-action configuration) and its development, to gain some indication on the users' interpretation, the circumstances under which it turned out as inappropriate and the resources deployed during the breakdown episode.*

For example, in one evaluation we carried out, we built a series of grids to guide the analysis of each breakdown episode. We built four grids each of them was analyzing the same episode from a different analytic focus (possible actions afforded by the environment, strategies to exit the breakdown, handling the interactive device).

Frame	Description of the breakdown episode	Circumstances of breakdown	Possible action	Comments
-------	--------------------------------------	----------------------------	-----------------	----------

Once all episodes have been analyzed, they have all been compared for similarities in order to draw up some general categories; the list of outlined categories has then been tested on another set of episodes and refined.

If the analysts want to reach a finer degree of analysis, for example because some episodes are intricate or some specific phenomenon are to be unearthed, they can carry out an interaction analysis (Jordan, Henderson, 1995; Ochs, 1996). As in the previous method, the detailed sequence of verbal and nonverbal actions is analyzed by looking at the resources that make this action recognizable as such and by tying them to the context in which they are performed. The difference is that the analysis proceeds utterance by utterance, move by move, trying to see how discursive practices already identified in the literature are used. Since this method time-consuming, evaluators may want to combine it strategically with faster solutions. For example:

- a deep exploration of a selected collection of cases and a faster examination of the remaining ones to check the interpretation and integrate the recurring results with new ones;
- a brief observation of all cases and then a deeper analysis of significant episodes;

- the adoption of the first stage of discourse analysis (transcription), as a means to empower the observational capacity of the evaluator: transcribing allows the evaluator to sharpen her view, so to speak, and have a remarkably greater closeness to the structure of the data.

This last method has been employed in another evaluation carried out by part of the authors and resulting in a narrative description of the most recurrent breakdowns with an emphasis on the relevant environmental elements involved and temporal details of interest; each description was accompanied by a correspondent suggestion to the designer.

The list of aspects the evaluator may want to pay attention to is endless. For example, the breakdown episode may be seen as a case of practical problem-solving, namely a spontaneous problem faced by the person engaged in a particular course of action, which causes that person to employ the available resources to solve it. It is a practical process because it does not start by elaborating mental solutions to be subsequently implemented into action, but by performing concrete actions in accordance to the affordances of the situation, in order to turn it into a more desirable one (Lave, 1988; Rogoff, Lave, 1984; Suchman, 1987). Those resources are various, ranging from a logic examination of the situation to ready, immediate moves. Distinguishing among this different kind of resources may be a good source of information. The availability of ready resources for example may be associated to the users' expertise or their growing familiarity with the VE. The kind of resources deployed to solve the breakdown can also sketch a picture of how generalization works, by indicating which circumstances are seen as similar and reacted to with similar strategies. The extent and criteria of generalization, in fact, should not be presupposed a priori, since more often than not what looks like a familiar situation to the evaluator strikes the user with puzzlement. This is illustrated in figure 2 below, which refers to two actions, namely turning to the left and moving laterally to the left (Figure 2). Some participants were not able to adopt for the latter the operation already employed for the former, treating the two actions as different and then associating them with different resources and possibilities.

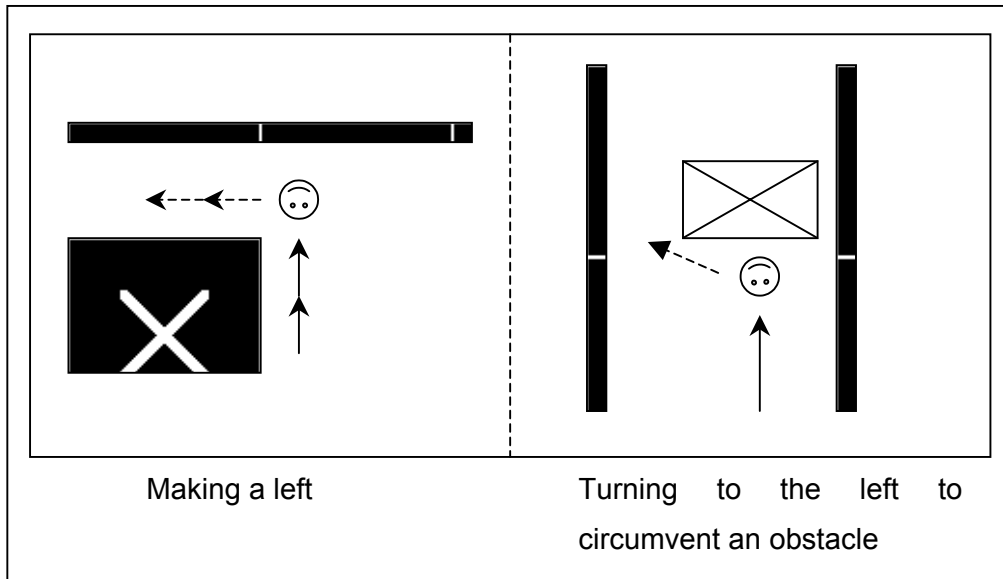

Figure 2

Finally, some strategies that can improve the quality of the breakdown analysis and are recommended for any qualitative method in general include the following:

- to *anchor* the interpretation to a set of synergic evidences, such as the local resources the actor is orienting to or the sequence of moves she performs.
- to consider *alternative* interpretations;
- to grow *familiar* with the context in which the interaction takes place
- to *confront* with other evaluators;
- to *broaden* the corpus of data with occurrences that the previous collection of episodes lack
- to adopt an *integrated* method of analysis that includes multiple techniques to address different aspects of the phenomenon
- to keep track of the choices made during the analysis and discuss them constantly (*reflexivity*)

In addition to the qualitative analysis we have dwelled on so far, the various aspects of the breakdown episodes may undergo quantitative analysis of various kinds, according to the questions that are relevant for the evaluator or the designer and can help reducing the costs in temporal terms associated with the deployment of a qualitative analysis.

Conclusions.

In this paper, we described the basic assumptions of a situated breakdown analysis and the kind of aspects to extract from the videorecorded data. The main advantages of this analysis are its closeness to data, the attention to contextual elements, the ability to handle both verbal and bodily actions. Breakdowns can be studied in order to redesign the system's affordances for a certain class of users and hence prevent misunderstanding on the functioning of the system; on the other hand, breakdowns represent a chance for the users to expand their knowledge of the technology (Winograd, Flores, 1986; Koschmann, 1990), so they can be administered deliberately in a customized training path.

Notes.

[1] The exhaustion of a course of action is not predictable a priori, since it can be extended no matter how completed the action seems at the moment and can be considered finished only when a new one starts. This criterion is borrowed from conversation analysis and its description of a sequence of talk-in-interaction.

References.

- Biggs S. J. (1983). Choosing to change in video feedback: On common-sense and the empiricist error. In P. W. Dourick, S. J. Biggs (eds), *Using video. Psychological and social applications*. Chichester: John Wiley and Sons, 211-226.
- Button G. (ed) (1993). *Technology in working order*. London: Routledge.
- Carroll J. M., Mack R. L., Robertson S. P., Rosson M.B. (1994). Binding objects to scenarios of use. *International Journal of Human-Computer Studies*. 41: 243-276.
- Carroll J.M., Neale D.C., Isenhour P.L. (1993). Critical incidents and critical themes in empirical usability evaluation. In *Proceedings of the BCSHCI93 People and computers VIII*, 279-292, Cambridge: Cambridge University Press.
- Ciborra C., Lanzara F. (1990). Designing dynamic artifacts: computer systems as formative contexts. In P. Gagliardi (ed) *Symbols and artifacts: Views of the corporate landscape*.
- Engeström, Y. and Middleton, D., Eds, (1996). *Cognition and communication at work..* Cambridge: Cambridge University Press.

- Engeström Y., Escalante V. (1996). Mundane tool or object of affection? The rise and fall of the postal buddy. In Nardi B. (1996). *Context and consciousness. Activity theory and human-computer interaction*. Cambridge, MA: The MIT Press.
- Engeström Y., Miettinen R., Punamäki R. (1999) (eds). *Perspectives on activity theory*. Cambridge, MA: Cambridge University Press.
- Flanagan J.C. (1954) The critical incident technique. *Psychological Bulletin*, 51 (4), 327-358.
- Gamberini L., Valentini E. (2001) Web usability Today: Theories, Approach and Methods. In G. Riva, C. Galimberti *Towards Cyberpsychology: Mind, Cognition and Society in the Internet Age*. Amsterdam: IOS Press.
- Gamberini L., Spagnolli A. (2002) On the relationship between presence and usability in virtual environments: A situated, action based approach. In G. Riva, F. Davide (a cura di) *'Being there'* Amsterdam: IOS Press.
- Greenbaum, J., Kyng, M., (Eds) (1991). *Design at work: Cooperative design of computer systems*. Hillsdale, NJ: Lawrence Erlbaum.
- Jordan, B, Henderson, A. (1995). Interaction Analysis: Foundations and practice. *The Journal of the Learning Sciences* 4(1), 39-103.
- Hutchins E. (1995). *Cognition in the wild*. Cambridge, MA: The MIT Press.
- Ihde D. (2002) *Bodies in technology*. Minneapolis, MN: University of Minnesota Press.
- Jordan, B, Henderson, A. (1995). Interaction Analysis: Foundations and practice. *The Journal of the Learning Sciences* 4(1), 39-103.
- Kling R. (1980). Social analysis of computing: Theoretical perspectives in recent empirical research. *Computing surveys*, 12: 61-110.
- Kling R. (1992) Behind the terminal: The critical role of computing infrastructure in effective information systems' development and use. In W. Cotterman, J. J. Senn (eds) *Challenges and strategies for research in system development*. London: Wiley.
- Koschmann T. 'Dewey's contribution to a standard of problem-based learning practice' available at <http://www.mmi.unimaas.nl/euro-cscl/Papers/90.pdf>
- Lave J. (1988). *Cognition in practice. Mind, mathematics and culture in everyday life*. Cambridge: Cambridge University Press.
- Law J. (1992) *Notes on the Theory of the Actor Network: Ordering, Strategy and Heterogeneity*. Available at: <http://www.comp.lancs.ac.uk/sociology/soc054jl.html>.
- Lea M. (1992). *Contexts of computer-mediated communication*. New York: Harvester Wheatsheaf.
- Luff, P., Gilbert, N. and Frohlich, D., Eds, (1990). *Computers and conversation*. London: Academic Press.

- Mantovani G. (1996). Social context in human-computer interaction: a new framework for mental models, cooperation and communication. *Cognitive Science* 20: 237-269.
- Mantovani G., Spagnoli A. (2001). Legitimizing technologies. Ambiguity as a premise for negotiation in a networked institution. *Information, technology and people*, 14 (3): 304-320.
- Nardi B. (1996). *Context and consciousness. Activity theory and human-computer interaction*. Cambridge, MA: The MIT Press.
- Ochs, E., Schegloff, E.A., Thompson S. A., Eds, (1996). *Interaction and grammar*. Cambridge: Cambridge University Press.
- Reason J.T. (1990) *Human error*. Cambridge: Cambridge University Press.
- Rasmussen J. (1980) What can be learned from human error reports?, In K. Duncan, M. Gruneberg, D. Wallis (eds) *Changes in working life*. London: Wiley.
- Rogoff B., Lave J. (1984) (eds) *Everyday cognition: Its development in social context*. Cambridge, MA: Harvard University Press.
- Shotter J. (1983). On viewing videotape records of oneself and others: A hermeneutical analysis. In P. W. Dourick, S. J. Biggs (eds), *Using video. Psychological and social applications*. Chichester: John Wiley and Sons, 199-210.
- Smagorinsky P. (1998). Thinking and speech and protocol analysis. *Mind, culture and activity*, 5 (3), 157-177.
- Stanney, K.M., Mourant, R.R. & Kennedy, R.S. (1998). Human factors in virtual environments: A review of the literature. *Presence*. 7 (4), 327-351.
- Steuer, J. (1992). Defining Virtual Reality: Dimensions Defining Telepresence. *Journal of Communication*, 42(4), 23-72.
- Suchman, L. (1987). *Plans and situated actions. The problem of human-machine communication*. New York Cambridge University Press.
- Suchman L. (1995) *Making work visible*. Communications of the ACM 38 (9) : 56-64.
- Wann, J. & Mon-Williams, M. (1996). What does virtual reality NEED?: human factors issues in the design of three-dimensional computer environments. *International Journal of Human-Computer Studies*, 44, 829-847.
- Winograd T., Flores S. (1986) *Understanding computers and cognition*. Norwood, NJ: Ablex.
- Zuccheromaglio C., Bagnara S., Stucky S. U. (eds) (1995) *Organizational learning and technological change*. Berlin: Springer Verlag.

TRANSCRIPTION CONVENTIONS

(base on the code elaborated by Gail Jefferson; for a broader version, refer to Ochs, Schegloff and Thompson, 1996, pp. 461-465).

- [[point of overlap onset at the start of an utterance
- [point of overlap onset
- = latched utterances
- (0.5) pause, represented in tenth of a second
- (.) micropause
- : stretching of the preceding sound
- ː falling intonation contour
- ˑ rising intonation contour
- ˒ falling or final intonation contour
- cut-off or self-interruption
- ↑↓ sharp rise/fall in pitch or resetting of the pitch register
- word emphasis; represented by the length of the underlining
- WORD especially loud sound
- ° softer sound
- hh marked expiration, whose length is represented by the number of letters
- (h) expiration within a word (e.g. while laughing)
- .h inspiration
- (()) transcriber's descriptions of events (e.g. cough, telephone rings,) or non-verbal actions
- >< compressed talk (rushed pace)
- <> stretched talk (slowed pace)
- (word) uncertain identification of the word
- (word A)/
- (word B) alternative hearings of the same strip of talk
- () inaudible talk; the distance among the brackets should represent the length of the missing talk
- , 'continuing' intonation
- ? rising intonation
- ˆ mild rising intonation

Web usability revisited: a situated approach

Giuseppe Riva[†]

Applied Technology for Neuro-Psychology Lab,
Istituto Auxologico Italiano, Milan, Italy

Centro Studi e Ricerche
di Psicologia della Comunicazione,
Università Cattolica del Sacro Cuore, Milan, Italy

ABSTRACT

The lack of usability is a problem for developers and companies: different studies of user behavior on the Web find a low tolerance for unusable sites. There is a simple motivation for this behavior: on the Internet, switching costs - how much effort it takes to switch from one provider to another - are low. If you don't find what you want, the competition is only a couple of mouse clicks away. Nevertheless, if most people agree about the need of usable web sites, there are no general theories about how web usability should work. If we check the most influential books on this topic we found different usability guidelines coming from authors' experience but no general theories to justify them. The aim of this article is to defining the starting points of a web usability framework based on the viewpoint of ecological realism. The framing assumptions of this new approach are one form of a general theoretical stance, which can be called *situativity theory*, in which cognitive processes are analyzed as relations between agents and other systems.

Keywords: *web usability, ecological approach, activity theory, usability guidelines.*

Received 20 June 2002; accepted 25 June 2002.

1. Introduction

What is usability? In 1998 the International Organization for Standardization defined *usability* as the effectiveness, efficiency, and satisfaction with which specified users achieve specified goals in particular environments (ISO, 1998). More in detail, *effectiveness* measures the accuracy and completeness with which specified users can achieve specified goals in particular environments; *efficiency* measures the resources

[†] Corresponding Author:
Giuseppe Riva, Università Cattolica del Sacro Cuore
Largo Gemelli 1, 20123 Milan, Italy
Tel: +39-02-72343734
Fax: +39-02-70034918
E-mail: auxo.psylab@auxologico.it

expended in relation to the accuracy and completeness of goals achieved; *satisfaction* measures the comfort and acceptability of the work system to its users and other people affected by its use (ISO, 1998).

In 2001, the International Organization for Standardization identified *usability* as one of the six characteristics (functionality, reliability, usability, efficiency, maintainability and portability) of software quality. In the document usability is defined as the capability of the software product to be understood, learned, used and attractive to the user, when used under specified conditions (ISO, 2001).

In this second definition we found three new concepts: *understandability*, the capability of the software product to enable the user to understand whether the software is suitable, and how it can be used for particular tasks and conditions of use; *learnability*, the capability of the software product to enable the user to learn its application; *operability*, the capability of the software product to enable the user to operate and control it (ISO, 2001).

The rationale behind these two definitions is clearly expressed by the Human-centered design (HCD) approach, whose main goal is incorporating the user's perspective into the software development process in order to achieve a usable system (ISO, 2001; Maguire, 2001). According to the ISO 13407 standard (ISO, 2001), human-centered design requires the following processes:

- Understand and specify the context of use;
- Specify the user and organizational requirements;
- Produce designs and prototypes;
- Carry out user-based assessment.

In the HCD approach, that has its origin in the seminal work of Norman and Draper (Norman & Draper, 1986), the focus is the “human”, also called “subject”, “user” or “customer”. As clearly stated by Vredenburg, Isensee & Righi (Vredenburg, Isensee, & Righi, 2002) “the centered part of User-Centered Design refers to the fact that aspects of UCD revolve around one center, the user.” (p. 20). Starting from him, the ISO 13407 standard (ISO, 2001) arranges separately different experimental conditions and analysis - related to the context of use, user requirements, design and evaluation of the tool (Maguire, 2001) - to obtain information about the different usability subsystems: effectiveness, efficiency, satisfaction, understandability, etc. It is hoped and expected that conclusions from these different processes can be used to build up understanding of the level of usability of a given tool. As noted by Gamberini & Valentini (Gamberini & Valentini, 2001), in this vision “the human cognitive system is

seen as a hierarchical structure made of various units, each of which handles a specific function.” (p. 112).

2. Ecological approach and Activity Theory

The last 50 years have been marked by strong scientific achievements in the study of perception and social interaction, including concepts and methods of ecological psychology, ethnography, ethnomethodology, discourse analysis, symbolic interactionism, and sociocultural psychology, which we refer to as *situativity approach* (Clancey, 1997; Greeno, 1998; Greeno & Moore, 1993; Suchman, 1987). According to this vision, cognitive processes are analyzed as relations between agents and other systems. As noted by Greeno (Greeno, 1998), “paradigmatic situations in this research include people communicating with each other as they plan and evaluate their activities and coordinate their interactions with each other and with material and technological systems... In particular the research focuses on interactive systems of activity in which individuals participate, usually to achieve objectives that are meaningful in relation to their more general identities and memberships in communities of practice” (pp. 5-6).

This theoretical shift does not imply a denial of individual cognition as a theoretically important process. It does, however, involve a shift of the level of primary focus of cognitive analyses from processes that can be attributed to individual agents, as usually happens in the Human-centered design approach (Maguire, 2001), to interactive processes in which agents participate, cooperatively, with other agents and with the physical systems that they interact with.

This vision is also the core of the *Activity Theory*. According to this theory basic unit of analysis of all human experience is “*activity*”, a broader concept than individual goal-oriented actions (Leontjev, 1981; Vygotsky, 1978). An activity is undertaken by a human actor motivated towards an object and mediated by a tool (also called “artifact”). Activities are distinguished from each other according to their *motives*, also called “objects” (hence the term “object-oriented activity”) (Kuutti, 1996). Activity Theory identifies two general kinds of objects: real, physical (material) objects and ideal (mental) objects, present in the subject's mind. Each activity is performed by several goal-directed conscious actions, that in turn are composed by task-oriented operations, usually non-conscious.

Another key feature of the Activity Theory is the active nature of the subject of an activity. The actors bring with them different characteristics that affect how they approach the activity: previous experience, cognitive skills, personality and culturally

determined traits. These will continue to evolve as the person undertakes the activity (Hasan, Gould, & Hyland, 1998). Finally, human activity always involves the use of tools: physical/material tools - such as computer - or psychological/cultural tools - such as language and ideas. The link between the actor and the tools is a two-way relation. On one side, tools shape the way human beings interact with reality. On the other side, tools usually reflect the experiences of other people who have tried to solve similar problems at an earlier time and invented/ modified the tool to make it more efficient. So, the use of tools is a means for the accumulation and transmission of social knowledge.

Another theory related to the situativity approach is ecological psychology. Key feature of this vision is that the environment is perceived in user-relevant terms, that is, in terms of what the user can do with and in the environment (Gibson, 1979). Perception is seen as an active pickup of meaningful information that specifies the behavioral possibilities of the environment, also called *affordances*. According to Gibson, affordances can be described as potential complementary relationships between the *actor* – a subject with specific goals - and environment. They indicate how the world could be acted on by the subject. Thus, action, viewed as the realization of affordances, is intimately related to perception (Greeno, 1994). A possible affordance of a web site could be "the ability to find the company fax number."

The affordances perceived have their counterparts in *effectivities* of the actor, the abilities required for exploiting the affordance. More precisely, effectivities are "the dynamic capabilities of that individual taken with reference to a set of action-relevant properties of the environment" (Zaff, 1995).

3. Web usability: a situated approach

Up to now, the study of complex actions such as the interaction with a web site has not been the focus of attention in the ecological approach. It has dealt primarily with immediate perception-action couplings such as posture maintenance and spatial orientation (van Leeuwen, Smitsman, & van Leeuwen, 1994). For this reason, can an ecological based usability approach deal with the characteristics of Internet interaction? The concept of affordances is not new to the world of usability. In a recent paper Don Norman, a well known name in the field of usability, wrote (Norman, 1999): "I originally hated the [affordance] idea: it didn't make sense. I cared about processing mechanisms, and Gibson waved them off as irrelevant. Then, Gibson started spending considerable time in La Jolla, and so I was able to argue with him for long hours (both

of us relished intellectual arguments). I came to appreciate the concept of affordances." (p. 38). In particular this concept, strictly linked to other two dimensions – conceptual models and constraints - is used by Norman in his book "Psychology of Everyday Things" (Norman, 1988) for understanding how to operate a novel device.

Later, Norman shifted the focus of his analysis from the concept of affordance to the one of *perceived affordance*: "When I get around to revising Psychology of Everyday Things I will make a global change, replacing all instances of the word "affordance" with the phrase "perceived affordance." The designer cares more about what actions the user perceives to be possible than what is true." (pp. 38-39).

Even if this position underlines a key idea for usability - designed, perceivable affordances can directly influence usability - this theoretical change is resisted by different researchers. As Flach (Flach, 1995) underlines, "[This] confuses the affordances of an object with the information that specifies the affordances." (p.6).

Following this point, our position differs from the Norman one in a key feature: affordances have a relational ontology. They do not exist as a function of either the web site or the actor alone, but *have existence in the interaction* between the capabilities and properties (goals, knowledge, resources, context, etc.) of the actor and the properties of the web site (contents, interface, links, etc.). For example the Sony web site may afford technical support by a MP3 user searching for the latest drivers for his/her player, or media relations by a journalist interested to the photo of the new portable computer.

Following this position, the production of affordances is the result of a complex interaction between behavioral, cognitive, and environmental factors. And this makes the definition of empirically measurable relationships between the actor and the web site a difficult achievement.

However a first step towards this goal is provided by Amant (Amant, 1999): affordances can be interpreted "in terms of the costs associated with the generation and execution of operators in a plan" (p. 317). More in detail, "Each operator in our representation has an associated execution cost. This is an extension of the classical planning problem space, in which a planning agent searches for a sequence—*any* sequence—of operators that satisfies the goal it is given. By taking cost into account, an agent can search for the least expensive course of action that satisfies a goal." (p. 327).

Extending this vision we can say that affordances can be interpreted in terms of the costs associated with the generation and execution of goal-oriented actions: affordances allow a reduction in the costs - physical and/or cognitive - needed for planning and executing a goal-oriented action.

However, affordances are only opportunities. The passage between the perception of the affordance and the action is mediated by a particular type of intention called *implementation intention* (Brandstätter, Lengfelder, & Gollwitzer, 2001; Gollwitzer, 1999; Gollwitzer & Brandstätter, 1997). In an implementation intention, an anticipated future situation (affordance) is linked to a certain goal-directed behavior. It has the following structure - *when situation x arises, I will perform response y* - and thus links anticipated opportunities with goal-directed responses.

If we integrate all the previous theories in a single framework we have the following model (see Figure 1):

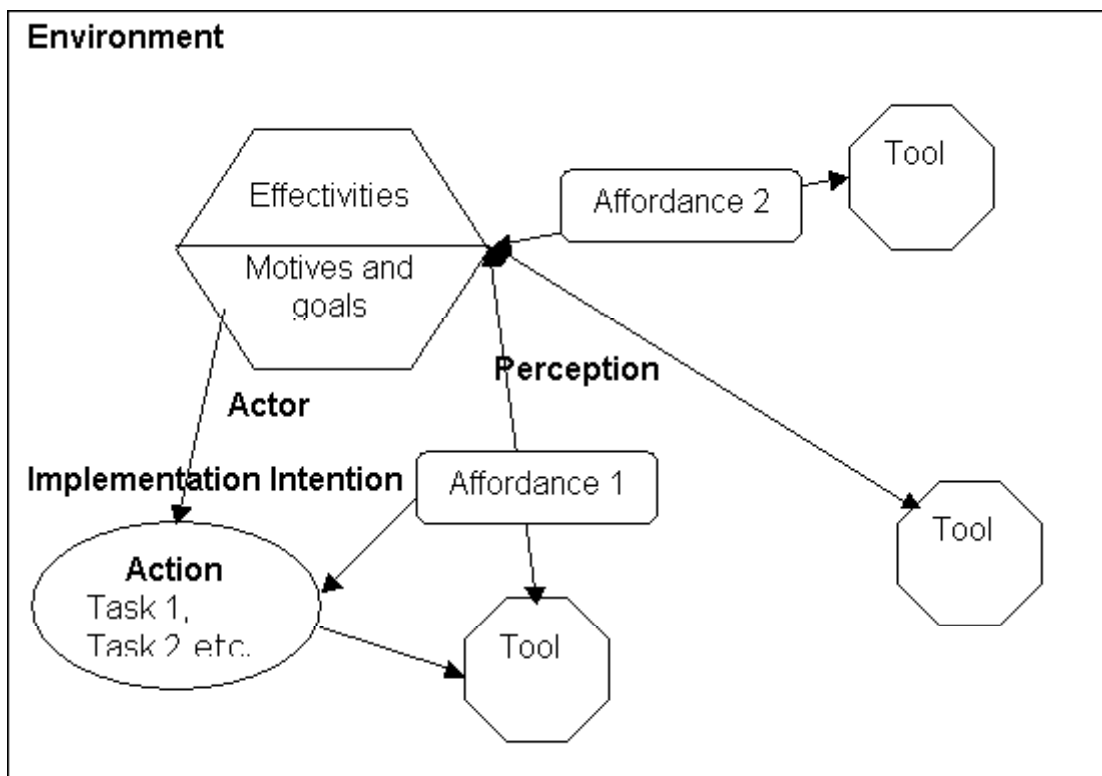

Figure 1: The situated evaluation model

- **the actor**, with specific motives and goals: *e.g., a journalist, during the preparation of an article on new technologies that could allow him to win the Pulitzer prize (motive), is searching for the fax number of Sony Europe (goal).*
- **an environment**, surrounding the actor, filled of different **tools/artifacts**: *the journalist is in his office, located in the journal main building. On the desks there are the yellow pages, a telephone, the Sony brochure received by mail a month ago, a computer connected to the Internet, etc.*

- the actor **perceives** some of the different tools around him: in his/her visual field he can see the computer and the telephone but not the yellow pages and the Sony brochure, covered by other books.
- the perception of the different tools informs the individual of **affordances**. An affordance is a value-rich ecological object that reduces the costs of a goal directed action by means of a tool: *Using the computer connected to the Internet the journalist can access the Sony web site and find the fax number easily. Otherwise he has either to search for the Sony brochure or the yellow pages. In this second case he also has to find the Sony Europe number, contact them, ask for the press office, contact it and asking for the fax number.*
- The perception of the affordances is related both to the motives/goals of the actor and to his **effectivities**. Effectivities are the possibilities/abilities to act on the tool for exploiting the affordance: *The journalist uses Internet every day and knows how to orient himself in corporate web sites in order to find easily the required information. However, a journalist without a previous experience of the web could find the research task impossible to accomplish.*
- The passage between the perception of the affordance and the action is mediated by **implementation intentions**. Holding an implementation intention commits the individual to the performance of a certain goal-directed behavior once the critical situation is actually encountered: *If the journalist cannot find easily the Sony brochure will use Internet for obtaining the fax number.*
- If different objects afford opportunities for action, the choice of the final action is related firstly, to the **relevance of the motive/goal** orienting it and secondly, to its **cost** – the more is the affordance, the less is the cost: *If the journalist, surfing on the Sony site find an interesting news, relevant for the preparation of the article (high level motive), can decide to stop the research of the fax number (low level goal) and read it. Moreover, if the research of the fax number on the web site is not effective may decide to stop it and search again the Sony brochure in the office.*

Following this approach we can propose a new definition of web usability: a web site is *usable* if it *allows a low cost exploitation of a significant affordance*. This definition, even if very simple, clearly identify a five-step framework for a web usability analysis:

1. *the subject should be able to perceive the affordance*: If I don't know that the XY web site offers a 50% reduction on portable computers I will never visit it
2. *the subject should evaluate this affordance as significant*: If my colleague who work in a computer shop can offer me a 45% price cut on portable computers I will probably skip the affordance offered by the site. The same if I just bought a new

portable computer last week. However, If I have to buy a new portable computer and no one can offer me a relevant price cut, the affordance becomes very interesting.

3. *the subject should be able to understand how to exploit the affordance*: If the 50% reduction is offered only by entering a promotion code I have no idea of where I can get it, after visiting the web site, I will probably pass by.
4. *the subject should be able to evaluate the effort required for the exploitation of the affordance as cost effective*: if the promotion code is given just after completing a registration form I can evaluate the effort required as adequate and fill the form. However, if I get the code just after buying electronic equipment for the same value of the discount offered, I may consider this effort as non cost effective.
5. *the subject should be able to effectively exploit the affordance*. Even if I evaluated the 50% reduction as significant, I understood how to get the promotion code and evaluated positively the effort required, I effectively exploit the affordance only after the successful purchase of the portable computer.

4. Conclusions

If we check the classical web usability books, it is easy to verify that most of the analyses done by usability experts is related to step five of the proposed framework. For instance, the well know Krug's first law of usability (Krug, 2000) – don't make me think – is not related to the perception or to the evaluation of the affordance but only to its final exploitation. For Krug, the main focus of the usability intervention is to create a web site in which the user can exploit the affordance without any conscious effort.

At the opposite, in our approach the focus of the usability expert is the perception and evaluation of the affordances: his main role is the perception of the affordances of a situation for others. This task is often underestimated because people are so proficient at judging affordances for themselves that they fail to recognize the difficulty in accurately assessing the affordances for others. In this sense the usability analysis is a process that requires simultaneously taking into account the structural and dynamic properties of individuals who will be using the web site and the structural and dynamic properties of the site.

In this paper we identified as key theoretical paradigms for a web usability theory the ecological approach and the activity theory. More in detail, we suggested some ways in which an extended version of Gibson's concept of affordance can be used in a situated theory of web usability. Gibson's theorizing was seminal in the development of ecological psychology and is likely to be seminal in a more general development of a

usability theory viewed as interactive relations of an actor with other agents and physical systems. The next step is a broader theory that merges these perspectives, along with the insights and methods of information-processing cognitive science.

References

- Amant, R. S. (1999). User interface affordances in a planning representation. *Human-Computer Interaction, 14*(3), 317-354.
- Brandstätter, V., Lengfelder, A., & Gollwitzer, P. M. (2001). Implementation intentions and efficient action initiation. *Journal of Personality and Social Psychology, 81*(5), 946-960.
- Clancey, W. J. (1997). *Situated cognition: On human knowledge and computer representation*. Cambridge: Cambridge University Press.
- Flach, J. M. (1995). The ecology of human machine systems: A personal history. In J. M. Flach & P. A. Hancock & J. Caird & K. J. Vicente (Eds.), *Global perspectives on the ecology of human-machine systems* (pp. 1-13). Mahwah, NJ: Lawrence Erlbaum.
- Gamberini, L., & Valentini, E. (2001). Web usability today: Theories, approach and methods. In G. Riva & C. Galimberti (Eds.), *Towards CyberPsychology: Mind, Cognition and Society in the Internet age* (pp. 109-125). Amsterdam: IOS Press.
- Gibson, J. J. (1979). *The ecological approach to visual perception*. Hillsdale, NJ: Erlbaum.
- Gollwitzer, P. M. (1999). Implementation intentions: Strong effects of simple plans. *American Psychologist, 54*(7), 493-503.
- Gollwitzer, P. M., & Brandstätter, V. (1997). Implementation Intentions and Effective Goal Pursuit. *Journal of Personality and Social Psychology, 73*(1), 186-199.
- Greeno, J. G. (1994). Gibson's Affordances. *Psychological Review, 101*(2), 336-342.
- Greeno, J. G. (1998). The situativity of knowing, learning, and research. *American Psychologist, 53*(1), 5-26.
- Greeno, J. G., & Moore, J. L. (1993). Situativity and symbols: Response to Vera and Simon. *Cognitive Science, 17*, 49-60.
- Hasan, H., Gould, E., & Hyland, P. (Eds.). (1998). *Information Systems and Activity Theory: Tools in Context*. Wollongong: University of Wollongong Press.
- ISO. (1998). *ISO 9241/11 - Ergonomic requirements for office work with visual display terminals (VDTs) -- Part 11: Guidance on usability*. Geneva: International Organization for Standardization.

- ISO. (2001). *ISO/IEC 9126 - Software engineering -- Product quality -- Part 1: Quality model*. Geneva: International Organization for Standardization.
- Krug, S. (2000). *Don't make me think: Common sense approach to web usability*. Indianapolis, IN: Que.
- Kuutti, K. (1996). Activity Theory as a potential framework for human-computer interaction. In B. Nardi (Ed.), *Context and consciousness: Activity theory and Human-Computer Interaction* (pp. 17-44). Cambridge, MA: MIT Press.
- Leontjev, A. N. (1981). *Problems of the Development of Mind*. Moscow: Progress.
- Maguire, M. (2001). Methods to support human-centred design. *International Journal of Human-Computer Interaction*, 55, 587-634.
- Norman, D. A. (1988). *The psychology of everyday things*. New York: Basic Books.
- Norman, D. A. (1999). Affordance, Conventions and Design. *Interactions*(5), 38-43.
- Norman, D. A., & Draper, S. (1986). *User Centered System Design : New Perspectives on Human-Computer Interaction*. Mahwah, NJ: Lawrence Erlbaum Associates.
- Suchman, L. (1987). *Plans and situated action*. Cambridge, UK: Cambridge University Press.
- van Leeuwen, C., Smitsman, A., & van Leeuwen, L. (1994). Affordances, perceptual complexity, and the development of tool use. *Journal of Experimental Psychology: Human Perception and Performance*, 20(1), 174-191.
- Vredenburg, K., Isensee, S., & Righi, C. (2002). *User-Centered Design: An integrated approach*. Upper Saddle River, NJ: Prentice Hall.
- Vygotsky, L. S. (1978). *Mind in society: The development of higher psychological processes* (Vol. Harvard University Press): Cambridge, MA.
- Zaff, B. S. (1995). Designing with affordances in mind. In J. M. Flach & P. A. Hancock & J. Caird & K. J. Vicente (Eds.), *Global perspectives on the ecology of human-machine systems* (pp. 121-156). Mahwah, NJ: Lawrence Erlbaum.

Educational interaction in distance learning: Analysis of a one-way video and two-way audio system

Marco Casarotti ^{♦*}, Luca Filipponi[^], Luca Pieti[^] and Riccardo Sartori[^]

[♦] Department of Developmental and Social
Psychology, University of Padua, Italy

[^] Department of General Psychology,
University of Padua, Italy

ABSTRACT

The basic definition of distance learning (DL) considers that the teacher and the students are separate in the spatial dimension and that this distance is filled by using technological resources. Recent technological developments, allowing an increasing level of interaction between users, have implicated a deep change in the educational system. Aim of these studies was to analyze the implementation of interaction in a DL system with one-way video and two-way audio channels and to investigate the effect of interaction on psychological variables. Final results suggest that the possibility of interaction in distance learning arouses a greater degree of attention, interest, participation, concentration, satisfaction and perceived efficacy. The distance modality with interaction takes his place at the intermediate level between the traditional face to face lesson and video-recorded lesson or distance learning without interaction. The possibility of interaction during the lesson is a basic factor for the success of a distance course.

Keywords: *distance learning, education, video system, audio system, computer mediated communication.*

Received 15 January 2002; received in revised form 3 July 2002; accepted 5 July 2002.

1. Introduction

In a situation of rapid technological and socio-economical changes, the educational system has had to face increasing requests in terms of formation and upgrade of know-how and professional skills. Numerous structures, both private and public, are answering this challenge developing distance learning programs.

The basic definition of distance learning (DL) considers that the teacher and the students are separate in the spatial dimension and that this distance is filled by using technological resources (Moore & Kearsley, 1996).

These resources could help working adults to obtain a university diploma, to avoid difficulties linked to physical handicaps, or to implement professional upgrade courses

[♦] Corresponding Author:
Marco Casarotti, Dipartimento di Psicologia dello Sviluppo e della Socializzazione,
Università degli Studi di Padova, via Venezia 8, 35131 Padova, Italy
Tel: +39-049-8276671
Fax: +39-049-8276600

without requiring expensive travels. For many years technological tools have not had a remarkable impact on instruction. Recent technological developments, allowing an increasing level of interaction between users, have then implicated a deep change in the educational system.

DL can be implemented in two modalities: synchronous and asynchronous. In the synchronous modality, the teacher and the students interact in real time, for example by means of a two-way video-conference. In the asynchronous modality, the interaction doesn't take place simultaneously. In this case, the teacher can send instructions via video, computer or other technological tools, and the students reply later. For example, instructions can be sent across the WEB and the feedback received via e-mail.

Many users wonder whether DL is as effective as traditional instruction face to face.

The studies comparing different teaching systems indicate that DL could be as or more effective than the traditional system.

In a research conducted at the Stanford University, Gibbons et al. (1977) have compared the scores obtained by subjects of different groups which had attended a course with different teaching modalities: campus, live video, videotape, videotape with tutor. Subjects in the last group reported better scores.

The Stanford TVI Experiments

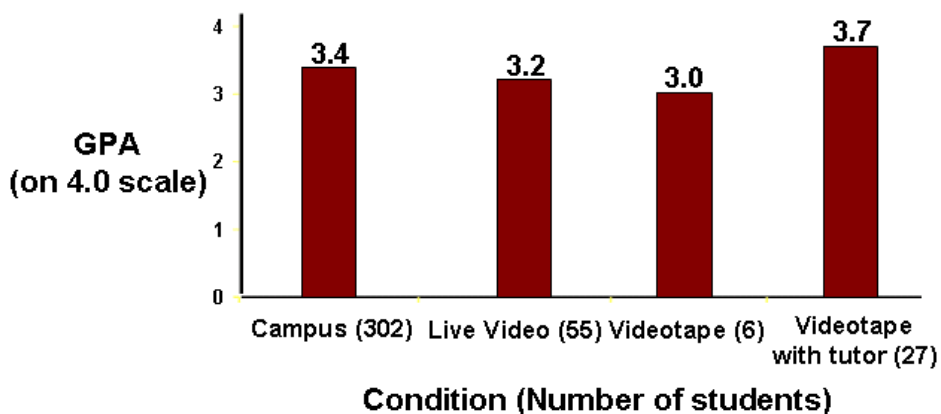

Figure 1. Modified from J. F. Gibbons et al. (1997).

A theoretical framework in which the psychological differences between traditional face to face teaching and DL can be analyzed is given by the Equivalency Theory (Simonson, 1998), which states that if the learning experiences of a traditional course are equivalent to the ones of a distance course, then the two courses will have the same results in terms of learning efficacy.

The learning experiences include all that happens in a classroom, for example lectures, practical activities and social interaction (SI). The mathematical representation of the Equivalency Theory describes the relation between learning experiences and equivalency:

$$\Sigma(\text{TC}) e_i = \Sigma(\text{DL}) e_i$$

where: TC = traditional classroom, DL = distance learning, e_i = learning experiences, e_1 = social interaction, e_m = practical activities.

The equation indicates that is the sum of the experiences which determine the equivalency. Thus, even if the detailed components could be not exactly the same, the final result remains equivalent.

The physical separation between teacher and students, and between students, is a potential source of SI decreases during the course. The SI is considered one of the most important factors which contributes to the efficacy of a course, both traditional and at distance (Moore & Kearsley, 1996). Therefore, a lack of equivalency in SI between TC and DL determines a difference in the success of the courses.

The Social Learning theory formulated by Bandura (1986) provides the mechanism by which SI affects the results of a course.

The Equivalency Theory takes into account also the individual differences in reacting to the same learning experiences. In the context of the SI, the individual differences could further alter the results of a course.

2. Implementation of distance learning

We briefly review the most widespread systems for implementing distance learning:

One-way video \ one-way audio

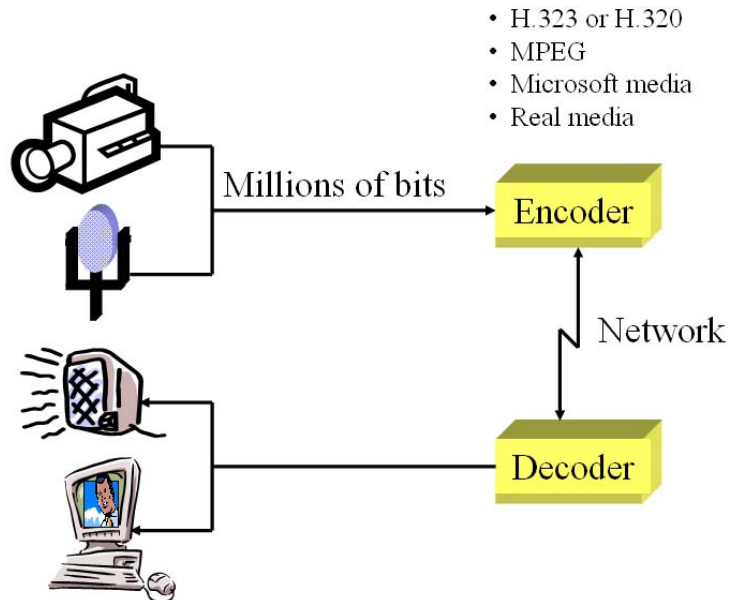

Figure 2. Modified from S. Poltrok (2002).

Videoconferencing

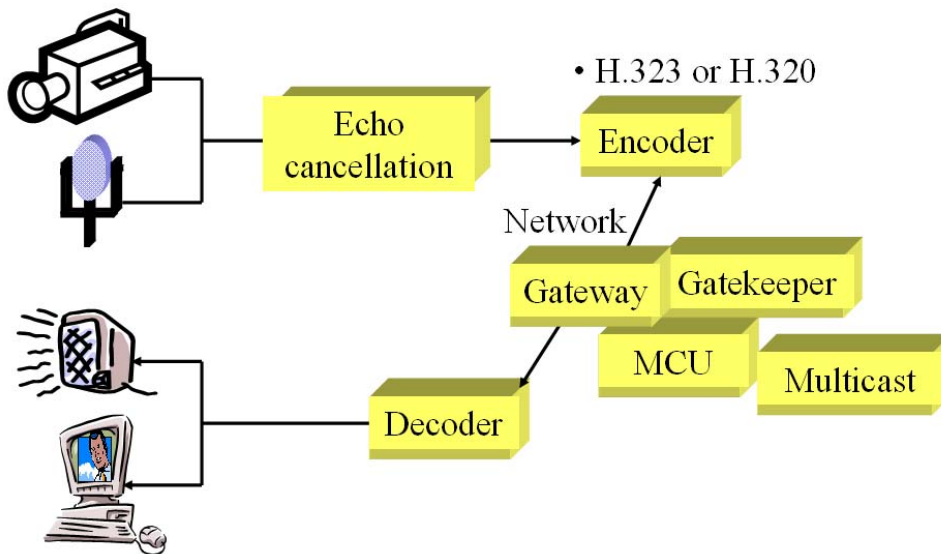

Figure 3. Modified from S. Poltrok (2002).

Video streaming

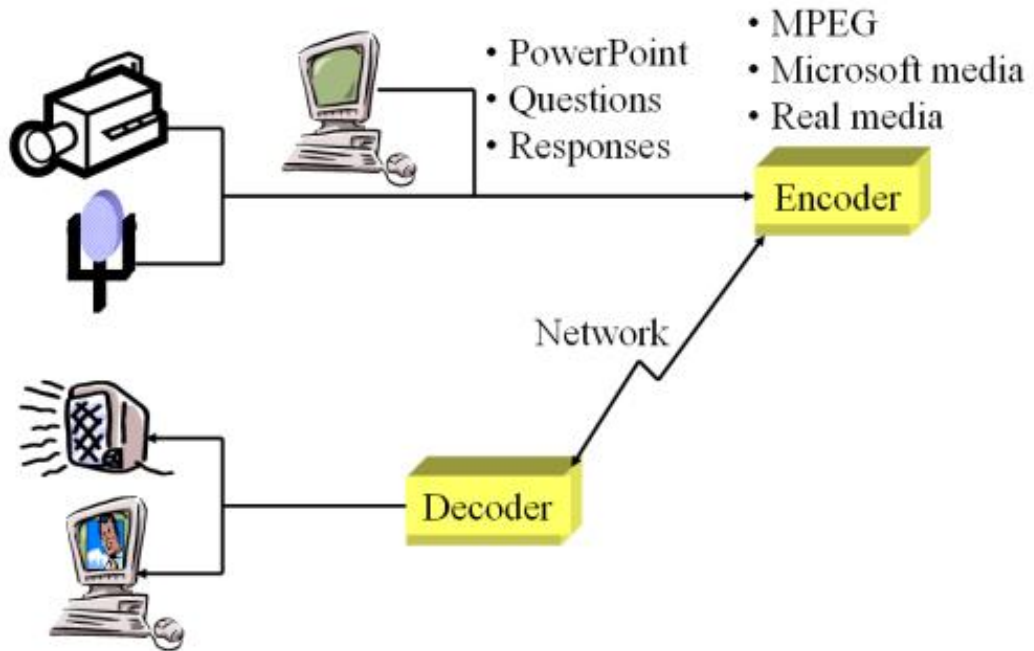

Figure 4. Modified from S. Poltrock (2002).

Video on demand

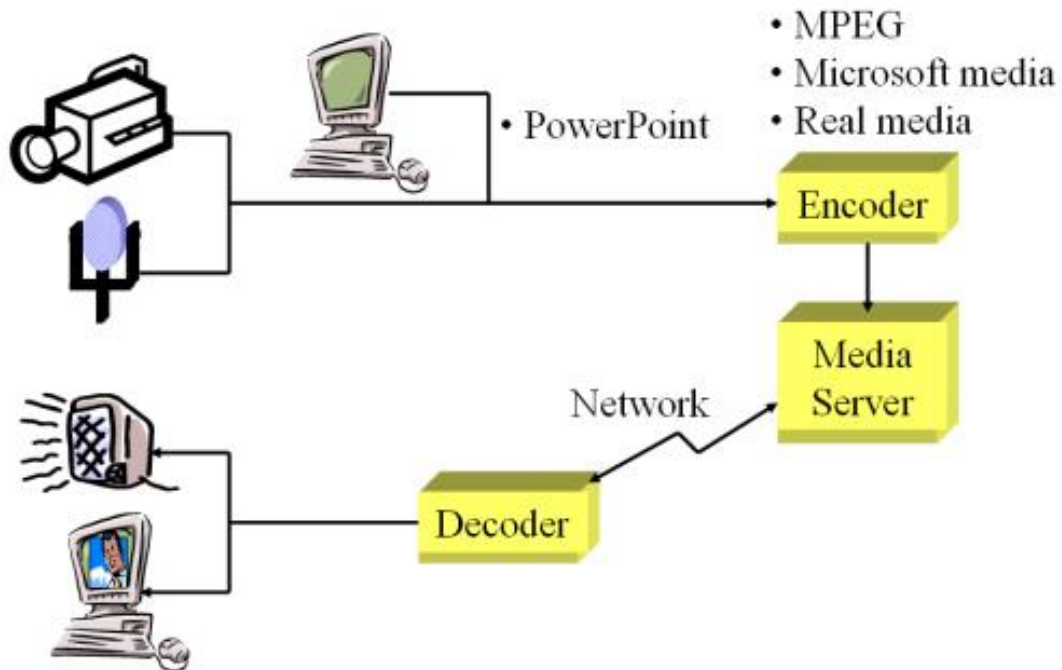

Figure 5. Modified from S. Poltrock (2002).

Considering the direction of the information flow, we can distinguish the following modalities:

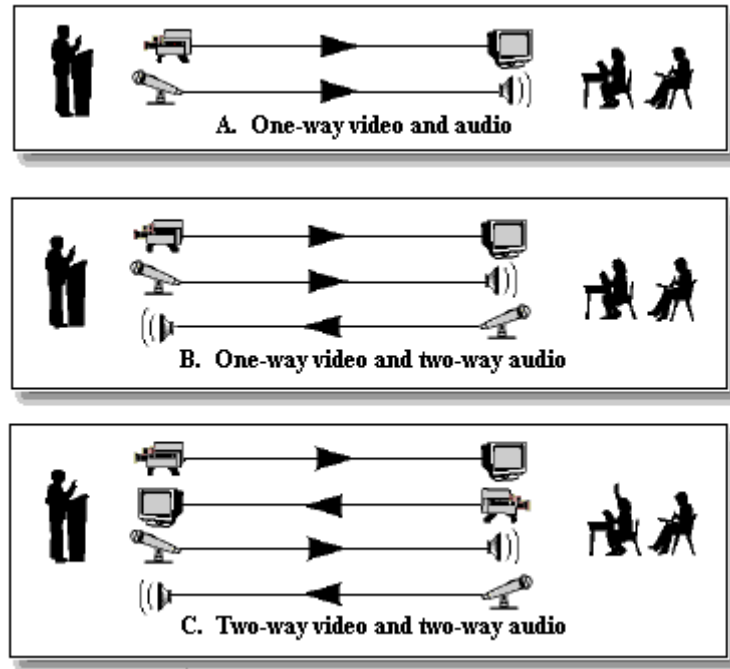

Figure 6. Different modalities of distance learning based on the direction of information flow.

The modality analyzed in our study was a one-way video \ two-way audio system based on satellite transference of the video contents:

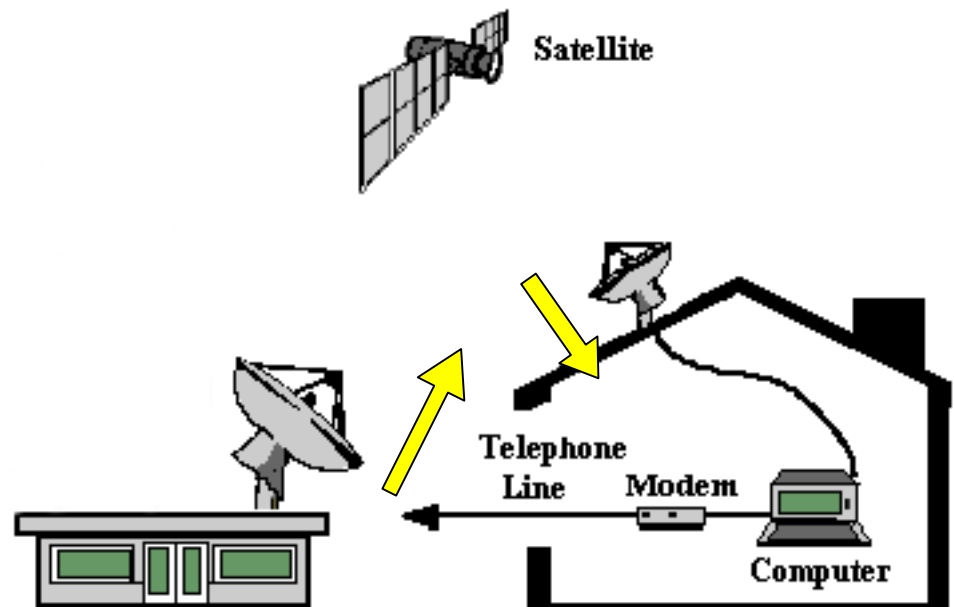

Figure 7. Representation of the system analyzed in this study.

3. Benefits of distance learning

Convenience

Technological tools implementing distance learning can provide advantages in terms of costs reduction both for the students and for the teachers; in fact, many usable technologies, for example internet, are easily reachable from home. Other tools, such as desktop videoconferencing, can be distributed from a single site, for example a university server, to many remote sites, for example classrooms. The satellite transmissions can be received from equipped positions, video-recorded and then used later.

Efficacy

Distance learning is not only convenient, but also effective. Several researches have demonstrated that, it can be equally or more effective than traditional instruction: when the method and the technologies are appropriate, when it is provided for the interaction between students and finally when there is continuous feedback between teacher and students (Moore & Thompson, 1990; Verdun & Clark, 1991; CSCL, 2002, available on-line).

Flexibility

Several distance learning systems allow the students to attend a course when they prefer, for example during the night or in the early afternoon. Moreover, a student may spend thirty minutes consulting a web site, while another may decide to appreciate the contents later on.

Multimediality

One of the most important advantages of distance learning regards the fact that a wide range of materials can be delivered respecting the individual preferences in the learning modalities. For example, some students prefer materials presented in visual or in acoustic form; others may learn better interacting with a computer program.

Interactivity

In contrast with the common opinion, distance learning can offer an increment in the interaction with students. In particular, introvert subjects who are too shy to ask questions in classroom, often are more active and participate when they can interact via e-mail or use another individualized tools (Franklin, Yoakam & Warren, 1996). By using interaction, besides, teachers can satisfy the individual needs of single students.

Equity

In many geographic areas, the lack of educational homogeneity is a real problem. The schools in the outskirts often have few teachers and out-of-date teaching tools. Distance learning allows these limits to be overcome and it has been used with great efficacy in countries such as Australia and Canada.

4. Effects of interaction in distance learning

At the Department of General Psychology of the University of Padua a research group (Educational Interaction in Distance Learning Laboratory, EIDLL) has been formed to investigate the effects of different types of interaction in distance learning: teacher-student and student-student.

Aim of the research group was to analyze qualitatively the implementation of interaction in a DL system with one-way video and two-way audio channels and to investigate the effect of interaction on psychological variables as, for example, the degree of satisfaction and perceived efficacy, the level of attention and distraction, etc.

The first studies have shown the remarkable impact due to the introduction and to the improvement of interaction in distance learning (Casarotti et al., 2002). These researches have provided important indications about the attitude and the degree of students participation during a distance lesson. Particularly, the student could interact: 1) virtually raising a hand by pressing a key; 2) addressing all the other students after the teacher's call; 3) answering multi-choice questions by pressing a key. Subjects who could interact with the teacher are more attentive during the lessons than subjects who attended the same lessons with no interaction. An identical situation was observed for the degree of interest, the degree of perceived satisfaction, the degree of participation and the level of concentration. Moreover, interacting subjects considered the lesson more effective than the colleagues who attended it with no interaction. As for distraction, the subjects in the interactive modality showed a lower degree of distraction than the subject in the passive modality.

In short, the results of our studies suggest that the possibility of interaction in distance learning arouses a greater degree of attention, interest, participation, concentration, satisfaction and perceived efficacy (fig. 8).

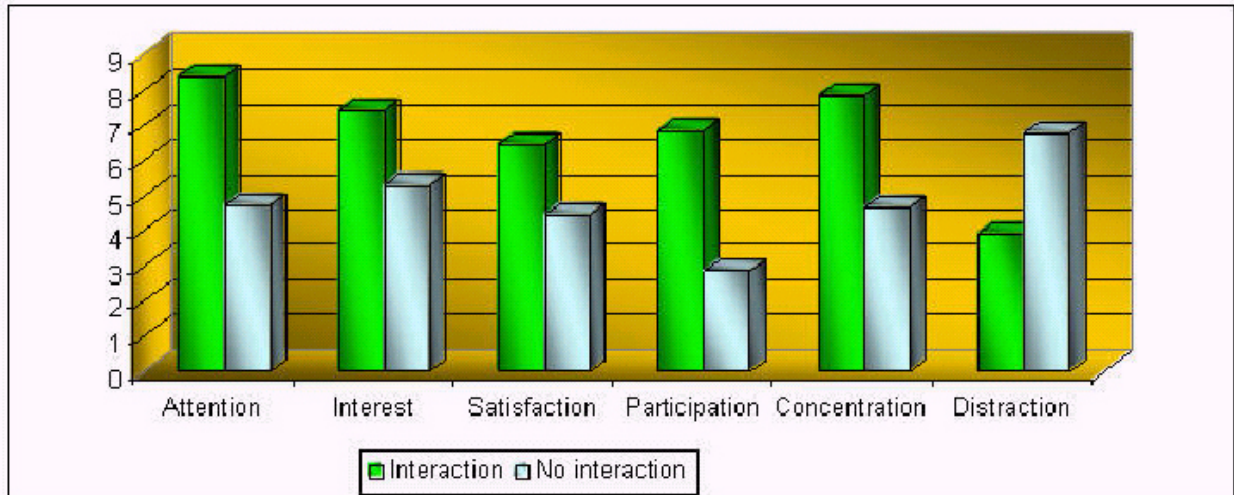

Figure 8. Effect of interaction on psychological variables.

These observations allow us to assume that the efficacy and the assessment of different systems implementing distance learning depends on the possible degree of interaction (fig. 9).

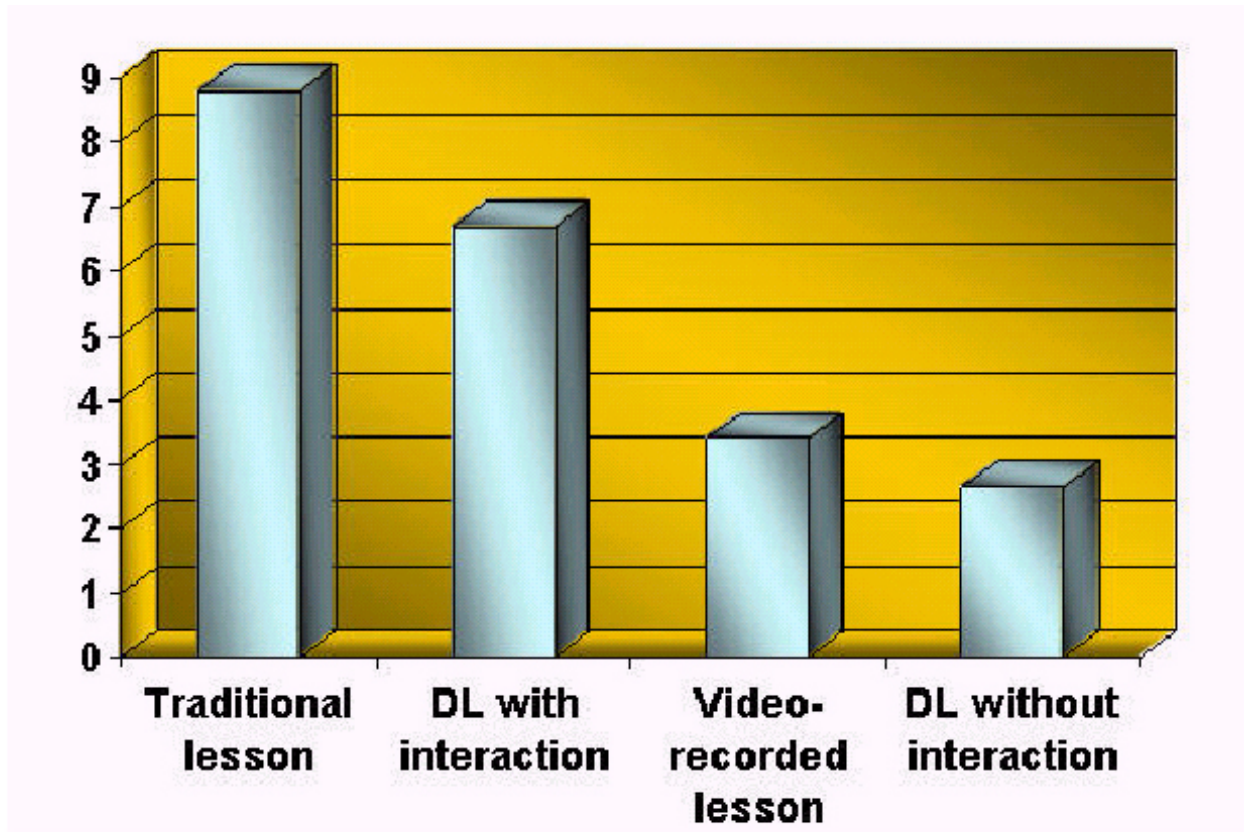

Figure 9. Assessment of different DL systems which differ in the degree of interaction.

It can be remarked that the traditional lesson is considered more positively than the video-recorded lesson or distance learning without interaction (asynchronous modality). At the intermediate level the distance modality with interaction takes his place such as that analyzed in our research. The interaction is crucial; we expect no differences between video-recorded lessons and that conducted at distance without any kind of interaction.

In conclusion, the possibility of interaction during the lesson is a basic factor for the success of a distance course.

The EIDLL intends to assess the quality and the amount of learning in a course at distance by means of new experimental studies manipulating the possibilities of interaction.

References

- Bandura, A. (1986). *Social foundations of thought and action: a social cognitive theory*. Englewood Cliffs, NJ: Prentice Hall.
- Casarotti, M., Filipponi, L., Pieti, L., Sartori, R. & Vidotto, G. (2002). *Ricerca e sperimentazione del sistema di formazione a distanza*. Rapporto tecnico, Laboratorio di Metodologia, Dipartimento di Psicologia Generale, Università di Padova, CSDL, Proceeding (2002), <http://www.csc2002.org/>.
- Franklin, N., Yoakam, M. & Warren, R. (1996). *Distance learning: a guidebook for system planning and implementation*. IN: Indiana University.
- Gibbons, J.F., Kincheloe, W.R., & Down, K.S. (1977). Tutored videotape instruction: A new use of electronics media in education. *Science*, 195, 1139-1146.
- Moore, M.G. & Kearsley, G. (1996). *Distance education: A Systems view*. Boston, MA: Wadsworth Publishing Company.
- Moore, M.G. & Thomson, M.M. (1990). The effects of distance learning: A summary of the literature. *Research Monograph No. 2*. University Park, PA: The Pennsylvania State University, American Center for the study of Distance Education.
- Poltrock, S. (2002). *Videoconferencing and collaborative groups*. Conference at University of Padua.
- Simonson, M. (1998). Equivalency theory and distance education. *TechTrends*, Vol. 43/Issue 5: pp. 5-8.
- Verdium, J.R. & Clark, T.A. (1991). *Distance Education: The foundation of effective practice*. San Francisco, CA: Jossey-Bass Publishers

Los Niños y las Tecnologías de la Información

Carlos Ruggeroni *

School of Psychology, National University Of Rosario, Argentina

ABSTRACT

Los efectos que la Tecnología genera en la Sociedad no son, en la Era Digital, una relación de causa-efecto unidireccional. Este artículo intenta elevar el interés científico sobre la relación que se genera entre la formación ética de los niños y el uso por parte de los mismo, de las tecnologías de la información. La organización del artículo muestra en su primera parte algunas de las diferentes teorizaciones acerca de la relación Sociedad Tecnología, para luego abordar la problemática que se presenta cuando los niños toman contacto con las tecnologías de la información. Este último, es el eje central de este trabajo: cuales son los efectos de estos usos en la formación ética y como se puede, responder frente a situaciones problemáticas. El aislamiento social, la competencia y la violencia, los derechos de autor y el desplazamiento de la toma de decisiones hacia las computadoras "inteligentes" son algunos casos típicos que aquí se presentan.

Keywords: *ethics, information technologies, children*

Received 1 May 2002 ; received in revised form 15 November 2002 ; accepted 18 November 2002.

* Corresponding Author:
Carlos Ruggeroni, School of Psychology, National University Of Rosario, Argentina.
Email: rosariovirtual@hotmail.com

Existe una gran cantidad de material bibliográfico (sobre todo en lengua sajona) acerca de estas problemáticas, que tratan de dar una respuesta un poca mas profunda que la noción de progreso que uso de estas tecnologías aporta a las Sociedades humanas. El éxito de la rápida incorporación de las tecnologías informacionales en la sociedad se relaciona con factores como el progreso y el confort que brindan a la población, existen otros aspectos de la sociedad que son afectados por esta incorporación rápida, aunque no son tan claros ni estamos todos de acuerdo con que sean tan beneficiosos. Algunos de estos aspectos puede n ser los aprendizajes espontáneos que los niños adquieren mediante el uso de las TI². Es importante señalar, que la rapidez en el desarrollo de estas tecnologías, aparece como una característica estructural de su desarrollo, lo que, como observadores del fenómeno, y también como protagonistas del mismo, nos pone en una postura de constante revisión.

1. Los efectos de la tecnología en la sociedad: La era post-determinista.

El determinismo tecnológico, como cualquier otro determinismo, adhiere a una relación unidireccional a la hora de hablar de efectos entre objetos determinantes y determinados. La Tecnología aparece, en este tipo de análisis, como modeladora de la Sociedad en una relación directa de causa efecto. Esta premisa teórica deja muy bien parada a la Tecnología, mientras que la Sociedad aparece como una especie de “esponja” que absorbe y se modela de acuerdo a los avatares de la tecnología. Pero, a medida que los niveles de interactividad dentro de las tecnologías informacionales aumentan, es decir ponen en evidencia que las decisiones, las formas de uso y difusión no dependen tanto de las tecnologías sino mas bien de los actores sociales, este paradigma, el determinista, aparece mas “naif” que explicativo. Con la intención de promover un análisis mas profundo la comunidad científica comenzó a aplicar modelos diversos. Expondré aquí algunos de los modelos mas usados, que verán han sido exportados desde otros ámbitos.

Edge (1995), Lyon (1995), Mackay (1995), Markus (1996), Dahlbom y Mathiassen (1996), acuerdan que el determinismo tecnológico deja afuera cualquier movimiento de los actores sociales que usan tecnologías, es decir no incluye como efecto a las intenciones de los usuarios. La acción entre tecnología y sociedad no es reciproca. La intención de este trabajo no es realizar un recorrido epistemológico arduo acerca de esta compleja trama, simplemente exponer algunas coordenadas sobre los puntos de vista en que diversas escuelas sociológicas trabajan este tema, para luego pasar al análisis de los cuatro items enunciados mas arriba.

² TI: tecnologías de la Información.

Es por esto que los diversos puntos de vista son expuesto aquí sinópticamente en la tabla n 1. Todos estas aproximaciones parten de una misma premisa, una postura critica acerca del paradigma determinista, la búsqueda de otro paradigma de análisis no es considerado en si un cambio político muchos paradigmas son reemplazados, reconstruidos aunque su sustrato político es el mismo.

Tabla n 1. Aproximaciones teóricas para interpretar la relación Tecnología-Sociedad. Sociología de la Tecnología.²

Fuente	Perspectiva	Aspectos Generales
	Determinismo Tecnológico.	Modelo lineal, los efectos en la sociedad son generados por la lógica interna de las nuevas tecnologías.
Edge	La Tecnología como un producción social.	Analiza los cambios tecnológicos como fruto de una interacción social, los cambios se generan por factores sociales y tecnológicos.
Lyon	La Sociedad se adapta a las Tecnologías.	La relación entre Sociedad y tecnología es considerada "problemática" ya que no esta organizada, los cambios se relación con una serie de variables que deben ser ajustadas en cada situación.
Mackay	<ol style="list-style-type: none"> 1. Tecnología con síntoma. (Williams) 2. Constructivismo Social. (Bijker) (Dahlbom and Mathiassen) 3. Redes conceptuales. (Hughes) 4. Actor Social. (Callon, Latour, Law) 5. Neo Marxista. (Braverman, Russel). 6. La tecnología afectada por las demandas sociales. (Winner) 	<ol style="list-style-type: none"> 1. La Tecnología es un síntoma del cambio social. 2. El quehacer científico es una construcción social. La Sociedad es influenciada por la tecnología. 3. La Tecnología es el resultado de un sistema que relaciona diversos grupos sociales. 4. El desarrollo tecnológico emerge de la relación entre los actores sociales los cuales son humanos y elementos no humanos. 5. Incluye aspectos socioeconómicos como variables de análisis. 6. Los efectos de la tecnología son resultantes del accionar de complejas fuerzas sociales que promueven diversos tipos de relaciones entre tecnología y sociedad.
Marques	<ol style="list-style-type: none"> 1. Actor racional. 2. Proceso Emergente. 	<ol style="list-style-type: none"> 1. Los efectos emergen no de las características materiales de las tecnologías sino de las formas en que estas son usadas por las personas. 2. Los efectos son consecuencia de inesperadas interacciones entre tecnología, usuario y valores.

² Estas conceptualizaciones fueron extraídas de: Mackay H. 'Theorising the IT/Society Relationship' in Heap N., Thomas R., Einon G., Mason R. and Mackay H., ed. (1995) *Information Technology and Society*, London, Sage.

Cada una de estas perspectivas intenta dar una respuesta a la búsqueda de nuevas perspectivas de análisis, sin embargo no es fácil salir de la postura determinista, que es una tendencia fuerte en la historia epistemológica humana. Además, es bastante difícil arribar a generalizaciones que podamos aplicar a todas las tecnologías de una vez. No es lo mismo el correo electrónico que un set de entrenamiento militar con realidad virtual.

Para el análisis aquí propuesto, será conveniente tener presente las distintas propuestas aquí enunciadas.. La postura de Markus, incluye la forma en que las tecnologías son usadas por las personas, también enuncia la posibilidad de que advengan interacciones inesperadas lo que incluye, si bien con un poco de ingenuidad una variable que merece la pena revisar.

2. Tecnología y Ética.

Los rápidos desarrollos, su rápida inclusión y las formas de uso de las TI en la sociedad generan problemáticas éticas. No es fácil discriminar que es un problema ético social, ni mucho menos si esta emerge fruto de la interacción con la Tecnología. Los aspectos éticos de un producto tecnológico deberían ser pensados durante la fase de diseño de dicho producto, aplicación o hardware, mas incluso si esto sucede, existe aun la posibilidad de interacciones no previstas, mal uso o abuso de la tecnología en cuestión.

¿Quién se hace cargo de las interacciones inesperadas?. Una aproximación simplista a un dilema ético tiene que ver con tomar una decisión correcta, esto quiere decir una discriminación entre el bien y el mal. Hay que aclarar que una situación dilemática se especificaría aun mas si decimos que es aquella en la que una decisión “conveniente” no es aquella que beneficie al resto de la sociedad sino solamente a la persona que se encuentra en la oportunidad de la decisión. Ocurre muchas veces, por no decir la mayoría de las veces que, las decisiones a tomar no son tan claras como simplísticamente aparecen entre el “bien” y el “mal”. Desde una perspectiva sociológica la ética tiene que ver con promover el bienestar general de la sociedad.

La Era Digital, que estamos viviendo en la actualidad, esta caracterizada por la multirelacionalidad de la información. Esto permite que el usuario construya rutas de preferencias dentro de esta red, mucho mas individualizables que con otros medios. Esta característica debe ser tomada en cuenta cuando hablamos de implicancias éticas en sus usos.

La responsabilidad sobre los efectos imprevistos en la ética de una sociedad no es solamente acuñable a un grupo sino a todas las partes involucradas, en este caso, los diseñadores y los usuarios. Por ejemplo, la relación de la sociedad con los medios masivos de comunicación es menos interactiva ya que el mensaje masivo es unidireccional, mientras que con las TI, la interactividad permite una serie de menús de los cuales servirse de datos para construir una información y luego conocimiento. En la era masiva el receptor se recostó en la pasividad de la recepción del producto construido, solo pudiendo aceptarlo o rechazarlo, ahora nos encontramos frente a posibilidades diversas.

Una de las características de la interactividad es que nos permite construir nuestro propio mensaje, podemos seleccionar las fotos, los textos, podemos editar lo queramos. Es bueno aclarar que las posturas éticas de la sociedad se han tramitado a través de todas sus construcciones, lo que cambia ahora es que se puede participar mas directamente en la producción de estos productos, y que además somos los activos responsables de lo que estamos tramitando allí. Queda obvio que el hacer no tiene ningún sentido, si este no es soportado por una actividad de reflexión, siendo en este punto los espacios de socialización tradicionales (familia / escuela) los responsables de permitir previo a todo hacer la capacidad de reflexión.

Si asumimos la hipótesis de que las TI van a cambiar la sociedad, no a la manera de un determinismo pero si como *proceso emergente*, como ha pasado con la revolución industrial y con la era mediática, podemos inferir también que la Sociedad está convocada a revisar sus códigos éticos, puestos en crisis por los procesos emergentes citados.

3. Soluciones propuestas a las problemáticas éticas planteadas .

Van Dijk (1999), nos expone el estado de situación:

‘We would expect the law to offer some protection, for the law is a sort of legitimised power. It is suppose to regulate power, or at least to prevent excesses. But the tragedy is that the law itself, particularly existing legislation, is itself being undermined by network technology. Better protection is needed; inadequate protection is the situation at present’ (pagina 115)¹

¹ Traducción del autor: “Esperamos que la ley nos de alguna protección, ya que la ley es un poder legitimizado. Se supone que regulara al poder o por lo menos previene excesos. Pero la tragedia es que la ley en si misma, particularmente las legislaciones existentes son minadas por las tecnologías de redes. Mejores protecciones son necesitadas, protecciones inadecuadas es la situación presente”

No toda problemática ética es a la vez una problemática legal, algunas problemáticas éticas involucran o devienen según la decisión tomada en una problemática legal. La legalidad está en ese caso, destinada a prevenir la recurrencia de una problemática ética. Las problemáticas éticas que emergen por el uso de las tecnologías informacionales carecen de soportes legales apropiados o de medios de control apropiados. Cuando la ley no dirige la solución ética, esta depende de la decisión del individual sea una persona o sea un colectivo.

Lo que sucede es que la postura ética pocas veces complace a la vez al interés personal, el que prevalece lamentablemente la mayoría de las veces. Esta conducta indica la presencia de otros problemas que anteponen la urgencia de su solución a una reflexión profunda de la situación, me refiero a por ejemplo problemas económicos.

Kallman y Grillo (1996) desarrollan esta idea en relacion a los niños:

'All of us address ethical decision with some sense of right and wrong. But many, specially young people, have had few opportunities to test their convictions' (pagina 7)²

Se proponen aquí algunas posibles soluciones; las soluciones legales, las soluciones de autorregulación, las protecciones tecnológicas y la Educación. Otro tipo de soluciones tienen que ver con las regulaciones legales respecto de los procesos de diseño. Pero tenemos que tener en cuenta que cuando se trata de los niños, no podemos esperar que un conocimiento de la ley sea intensivo o suficiente. A determinados niveles de maduración, los requerimientos de abstraccionismo para poder interpretar leyes generales, los conocimientos o acceso a leyes específicas no están dados o facilitados, por eso, sin ser ingenuos ni proteccionistas con este grupo social, se sugiere aquí a la Educación como la que debería hacerse cargo de formalizar todos los tipos de soluciones posibles y hacerlas accesibles a todos los niveles.

3.1. Soluciones legales.

Los problemas para este tipo de soluciones son el factor tiempo y el factor innovación. Las leyes necesitan de un tiempo para su creación, desarrollo e implementación. Comparada con la rapidez en que las TI se desarrollan y perfeccionan, algunas leyes pueden resultar inefectivas. Dentro del plano legal existen leyes que son generales, como la Constitución y otras específicas, como los códigos éticos de cada profesión, los cuales difícilmente cubran aspectos del quehacer digital de cada una de ellas. Uno

de los fundamentos universales de la ley es que “cualquier actividad que no este prohibida por la ley es legal”, esto abre otro capitulo sobre esta problemática ya que, muchos dilemas éticos no serán comprendidos bajo ningún marco legal específico, o por el momento carecen del mismo.

Reseñando a Kallman y Grillo (1996):

“Everyone has the obligation to understand ethics. Making ethical choices is part of everyday life, specially for those who used and create information technology.”(pagina 19)³

3.2. Autorregulaciones.

Esta solución parece ser la mas efectiva al momento, pero no es suficiente. Las autorregulaciones tienen que ver con las decisiones personales que los individuos seleccionan de acuerdo a sus propios códigos éticos. Subsecuentemente, se relaciona con el conocimiento general de la ley, que una persona o un grupo determinado asume como cierto. La mayor efectividad de este tipo de solución se da durante el proceso de diseño. Podemos inferir que las tecnologías informacionales afectan dramáticamente los códigos éticos de la sociedad, pero no solo se trata del diseño de un producto informacional, sino también como alude Kling (1994) quien incluye la “usabilidad” como una variable relevante:

“The Computer Science community needs an institutionalized research to produce a reliable body of knowledge about the usability and value of computerized systems and conditions under which computers system improve organizational performance” (pagina 33)⁴

Los Códigos de Conducta internos de las grandes organizaciones son autorregulaciones colectivas, otros ejemplos son las “hot-lines”. Estas soluciones son las mas efectivas y constituyen pasos previos para la posible instauración de una ley, pero no son soluciones definitivas. Es relevante decir que en los niños esta solución es la menos efectiva.

² “Todos nosotros tomamos decisiones éticas donde adscribimos a una política del bien y del mal, pero muchos especialmente los jóvenes tiene pocas oportunidades de testar sus convicciones.”

³ “Todos tenemos la obligación de entender a la ética, tomar decisiones relacionadas con posturas éticas es una situación cotidiana, en especial para aquellos que usan y crean tecnologías informacionales”

⁴ Los cientistas de la computación necesitan investigar en forma sistemática para producir un confiable conjunto de conceptos acerca de la usabilidad y valores de las sistemas computacionales y de las condiciones mediante las cuales estos sistemas mejoraran el funcionamiento de las organizaciones.”

3.3. Soluciones técnicas.

El uso de este tipo de soluciones representa, un retroceso de la sociedad y una avance de las tecnologías informacionales en el proceso de toma de decisiones que al estar directamente relacionadas con conductas éticas, son a la vez decisiones políticas. Este tipo de decisiones debe emerger de los pactos sociales entre los diferentes grupos componentes de una sociedad dada, mas una solución técnica, representa la centralización del poder de la tecnología que puede habilitar o inhibir ciertas conductas. Con este tipo de proceder, retornamos y reforzamos los determinismos y la centralización de poder en aquellos que acceden a los diseños de por ejemplo, productos multimedia les, redes electrónicas, etc. Hay que señalar que las soluciones tecnológicas previenen del uso indebido de estas tecnologías en forma efectiva, mas su instauración no da espacio para ningún debate social, o este debería existir y autorizar su uso.

Los filtros y el v-chip (violence chip) son uno de los mas conocidos dispositivos que se usan como soluciones técnicas. El problema de estas soluciones es que aun no están reguladas por la ley, es decir tanto pueden servir para prevenir conductas no éticas como pueden ser usados para otros fines. Hay que tener en cuenta que lo que aquí se trata es del manejo de la información, esto abre el debate de la libertad en que esta puede transitar por la red. Como vamos viendo no existe una solución efectiva.

3.4. Capacitación de la comunidad informática.

Otro tipo de solución es la capacitación de la comunidad informática, de los diseñadores, programadores del científicos, etc. La formación de los profesionales dedicados al diseño de soluciones informáticas carece de una perspectiva social y legal. Las problemáticas éticas en computación a la fecha aparecen como problemas colaterales "side effects". La relación que la sociedad establece con la información que maneja no debería ser considerada un efecto secundario, sino mas bien un problema de base. Reseñando a Kling:

"The dominant paradigms in academic computer science do not help technical professionals comprehend the social complexities of computerization, since the focus on computability, rather than usability". (pagina 34)

3.5. La educación de los niños sobre este tema.

La Educación formal puede se la gran protagonista cuando se trata de darle una respuesta a esta problemática. La Educación Ética no es solamente el nombre de una

materia mas en la curricula, sino que esta atraviesa todos los campos educativos formales y no formales, es decir, es un proceso implícito en cada acontecer del proceso dato→información→conocimiento. A la vez la problemática demanda de un espacio especifico donde este proceder se pueda poner en evidencia para una observación critica.

Para resumir, podemos decir que la problemática ética se hace manifiesta cuando los mecanismos de control se tornan ineficientes en el ciberespacio. Cinco tipos de solución se plantean aquí. Ninguna de las cinco puede dar respuestas definitivas, una implementación estratégica de las mismas podría ser mas efectiva. Estratégico en este caso tiene que ver con la combinación de estas soluciones en diferentes formas cualitativas y cuantitativas. El uso de estos reguladores debería además ser un patrimonio publico.

Figura 1. Problemáticas éticas emergentes de la relación tecnologías informacionales-sociedad

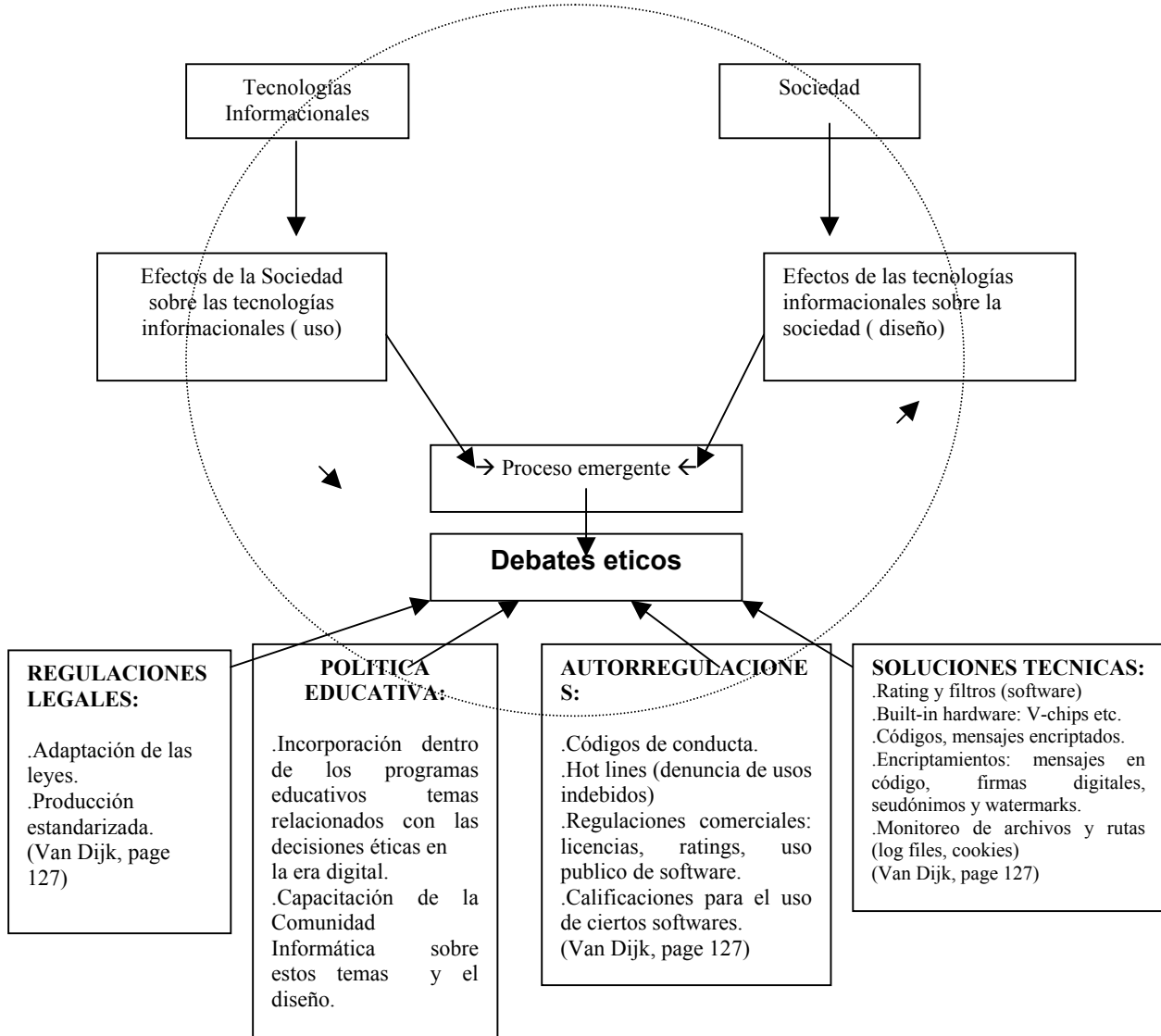

4. Los problemas concretos.

Vamos ahora a ver cuatro situaciones concretas. En algunas de ellas el factor ético aparece menos claro que en otras. La Ética, en un amplio sentido, se inscribe en cada conducta que ejecuta el sujeto en la sociedad.

4.1 Aislamiento social.

Es un problema ético? Es un problema legal ? Es una situación psicológica? Hasta cierto punto podemos decir que esta situación se transformara en problemática ética si es que se puede comprobar que las computadoras y sus aplicaciones son generadores de aislamiento social o no.

Usamos las tecnologías informacionales en prácticamente todos los ámbitos, en el laboral en el educativo y en el hogar. Mientras que en el laboral y educativo la situación aquí planteada esta mas contenida por los usos que se le dan en estos ámbitos, en el hogar la situación puede ser distinta. Mientras que en el ámbito laboral y en el educativo el uso de las computadoras y otras tecnologías se encuentra regulado por las políticas y procedimientos que regulan su practica, en el ámbito hogareño, la situación no se encuentra regulada mas que por las formas de uso de los usuarios. Este ámbito, que se considera "privado", no nos permite un campo de acción significativo ya que estaríamos invadiendo espacios de libertad. La situación pasa a ser entera responsabilidad de los sujetos sociales y en el caso de los niños de sus tutores.

Lo que se puede decir es que mientras que las tecnologías informacionales aportan velocidad y eficiencia a la sociedad, generan una disminución en el numero de interacciones directas entre los sujetos, eso se aplica a todos los ámbitos, puede aumentar la comunicación mediatizada por estas tecnologías pero disminuye la interacción sujeto-sujeto. La comunicación electrónica entre sujetos tampoco va a reemplazar la comunicación directa, hasta ahora, los dispositivos para comunicarnos electrónicamente carecen de la cualidad necesaria como para compararse a la comunicación directa entre sujetos, y cuando esto suceda habremos logrado técnicamente un optimo nivel del sentimiento de "presencia" esto es en palabras de Lombard y Ditton (1996) "la ilusión de no mediación", es decir la percepción de la realidad virtual optima.

Volviendo al tema, la comunicación mediada electrónicamente no nos permite transmitir la información contextual ni periférica, tan importante en los procesos informativos y comunicativos, los gestos, los movimientos de los ojos, el tono de la voz no se pueden enviar por mail, y constituyen valiosas herramientas referenciales de la comunicación. Cabe aquí señalar la importancia en los niños de todas las formas de comunicación pre verbales en los procesos de subjetivación.

Desde otro perspectiva, la comunicación electrónica permite que los sujetos que se encuentran en distintos continentes se comuniquen asiduamente.

En veinte años la velocidad de incorporación en la sociedad de las computadoras, cambio drásticamente. En los 80', investigaciones sobre aislamiento social identificaban a los usuarios de computadoras como a hobbistas, Michie (1980), mas adelante Turkle (1984), Shotton (1989) quienes también investigaron acerca del aislamiento y las computadoras definieron al grupo de uso como "computer dependants" entre los cuales se encontraban los kackers, players, etc. En los 90' la situación vuelve a cambiar ya que el numero de usuarios es tal que las categorías dadas carecen de operacionalidad, los estudios sobre aislamiento ahora se centraron en las características de la personalidad, donde el aislamiento pasa a ser un síntoma de ciertas personalidades o caracteropatias, como la depresión o la neurosis (Katz 1995), donde la computadora podría ser solo un medio de expresión sintomático. Al inicio del presente siglo el punto de observación son las características de la comunicación electrónica y las formas de mejorarlas. Técnicas como "collaborative learning with computers" (Dillemburg 1999) son propuestas tanto para facilitar procesos de enseñanza como para evitar el aislamiento en espacio áulicos. El aislamiento en relacion a estas tecnologías también pudo observarse mediante el "bache generacional" que genero en décadas anteriores donde los adolescentes manejaron las computadoras primero que los adultos.

En suma, el aislamiento social parece no ser una problemática que se relaciona con las tecnologías computacionales. Pareciera ser que el uso de estas tecnologías disminuye los contactos "cara a cara" entre los sujetos aumentando las comunicación mediada por interfaces electrónicas. Para contrarrestar este efecto las interfaces electrónicas intentan perfeccionarse, hablamos de la tele conferencia y de la realidad virtual. La educación con computadoras también intenta dar una respuesta a esta problemática proponiendo modelos de enseñanza grupales. Podemos decir, hablando de los niños, que cada vez que en sus casas se ponen en frente de una computadora reducen el tiempo de interacción humana concretamente. En este caso las autorregulaciones emanadas de los tutores, serán la forma mas simple y efectiva de regular esta situación.

4.2. Competencia y Violencia.

Una primera aproximación a esta problemática es la de tender una línea que conecte a la competencia con la violencia y que las separe también, esta barrera debe ser instrumentalizada tanto conceptualmente como operativamente. La velocidad y el rápido análisis de la información son considerados en la actualidad factores que facilitan la búsqueda y obtención de una identidad laboral.

El acto de jugar en los niños no es solamente un ejercicio catártico, el juego en la infancia constituye el escenario social donde los niños practican sus habilidades, desarrollan sus potencialidades previo al ingreso a la sociedad adulta. La escuela constituye dentro de esta perspectiva otro escenario, regulado con los valores que la sociedad intenta sostener. El escenario de juego no está tan controlado por la intervención directa de los adultos como lo es el escenario educativo. El escenario de juego social es construido a partir de las representaciones que los niños van construyendo a partir de las interacciones cotidianas. La metáfora juego representa esta percepción y marca las pautas de la vida en sociedad como adulto de las generaciones venideras.⁵ De aquí la importancia, relevancia del juego, su efectividad como hechos formadores. Esta efectividad tiene que ver con las ligaduras de estas actividades con el placer y la satisfacción que generan durante su accionar. Los juegos electrónicos, muchas veces, y cada vez más, borran la también metafórica barrera entre juego y realidad, esto, mezclado con la violencia y la competencia que estos juegos implícitamente o explícitamente activan, componen un problemático desafío para la educación ética. La competencia en la sociedad occidental funciona motorizando muchas intencionalidades del quehacer humano, la competencia permite el desarrollo de ciertas actividades productivas. La violencia no estaría tan ligada a la competencia en este sentido, es decir no sería un estadio intenso de la competencia. Entonces, jugar y los juegos electrónicos cumplen una importante función simbólica en los niños, quienes mientras están jugando, se están preparando para moverse dentro de una sociedad cada vez más compleja: la sociedad de redes, donde las tecnologías informacionales marcan ciertas pautas y proporciona los elementos de juego, de trabajo, de educación.

Este no es una novedad para la "net-generation" ya que su entorno es el tecnológico, la tecnología es un "determinado" (Ellul, 1964) tal como lo es el nombre o la ciudad donde se nace. Considero que los niños deben estar preparados para poder comprender la complejidad de la sociedad en la que están viviendo, atravesada por la tecnología, pero dentro del marco de esta labor, la educación deberá reseñar las diferencias entre fantasía y realidad y entre competencia y violencia de modo de evitar confusiones que pueden terminar en graves incidentes.

Los juegos competitivos y violentos existen anteriormente a la era digital, lo que tenemos que pensar es en reconceptualizar a la realidad. Los juegos electrónicos pueden ser un primer contacto de los niños con las tecnologías informacionales, las cuales reaparecerán en su vida escolar y laboral, pero esto no quiere decir que sea la única actividad que desarrollará capacidades reflexivas en el niño, muy por el

⁵ Hay que aclarar que en el juego se tramitan conflictivas psicológicas, pero que aquí nos interesa la faz social de esta compleja

contrario, muchos juegos electrónicos responden a entrenamientos mecanicistas. Nuevamente la educación será la encargada de promover la capacidad discriminatoria entre estos espacios electrónicos.

4.3.La propiedad intelectual.

Constituye uno de los grandes problemas éticos que emerge en la era digital, pero no por un interés solamente ético, mas si un interés económico de cifras incalculables. La información en formatos electrónicos es fácil de reproducir y de redistribuir y difícil de controlar, esto genera perdidas inmensas en los mercados editoriales. La posturas acerca de esta problemática varían de la búsqueda de leyes y protecciones electrónicas fuertes hasta proclamar la irrelevancia del Copyright (Langham 1993). Menos técnico y mas filosófico es el planteo acerca de quien tiene la autoría de los productos electrónicos, ya que el usuario puede cambiarlos a su estilo siendo el autor desplazado en su función primaria. La idea del Copyright es fuerte es países de tradición capitalista pero poco influyente en países con tradiciones socialistas, esto no hace fácil una legalidad global, que es lo que tendría que implementarse. La idea de propiedad privada no es la misma pese a la globalización en todo el mundo, (Van Dijk, 1999):

‘On the one hand many people consider information to be a social product that should not be exclusively appropriated by private interests. On the other hand, information has become one of the most important economic product in the modern economy and it should therefore be submitted to the principles of the market economy like any other good’ (page 129)⁶

Los niños no solo deben comprender el derecho a la propiedad intelectual sino también el valor de un bien totalmente abstracto como lo es la información, aquí no estamos hablando de poseer información sino de manipularla, comprenderla, procesarla, editarla, construirla. La interacción con producciones digitales es mas intensa que sobre otros formatos. Debemos entender a estas posibilidades editoriales como a formas creativas nuevas donde la representación del dato es también un proceso educativo relevante. Este es el espacio en que los niños crecen, la educación deberá enfocar no solo en la problemática ética sino en entender nuevas posibilidades creativas, relacionadas con estas características de los formatos digitales.

actividad representacional del sujeto.

⁶ “Por un lado mucha gente considera a la información como a un producto social que no debería ser patrimonio de intereses privados, por el otro lado, la información es uno de los productos económicos mas importantes de la economía moderna y por lo tanto debería estar sujeto a las regulaciones económicas que se le imponen a cualquier mercadería”. T.d A.

4.4. El desplazamiento de la toma de decisiones sobre computadoras “inteligentes”.

La inteligencia artificial constituye una de las ramas más polémicas de la informática, la inteligencia artificial intenta digitalizar los procesos lógicos del pensamiento humano, este es un concepto reducido de inteligencia!

Sin embargo, los programas de inteligencia artificial se hallan desarrollados y funcionando a niveles muy sofisticados de labores humanas, los más conocidos son los agentes o tutores de

programas de entrenamiento y también los programas que se usan en los ámbitos médicos y que sirven para diagnosticar cuadros clínicos. Los desarrollos en Inteligencia Artificial no han sido tan rápidos como se esperaba, dada la gran complejidad del pensar, en los 80' la interacción entre el hombre y los programas de inteligencia artificial generaron preocupación, parafraseando a Michie (1980):

‘Apart from military applications, dangers can be seen in loss of stability in social control mechanism, increasing dependency and decreasing comprehension on the part of the user population and loss of stability and loss of independent will and vital impetus by mankind at large.’ (pagina 141)

Luego de 20 años de desarrollos en IA, la situación cambia, ya que la tecnología tiende a reducirse en tamaño, gracias a la evolución del hardware, la miniaturización del hardware permite pensar en un proceso de simbiótización entre hardware y ser humano, dentro de esta perspectiva la responsabilidad estaría dentro del nuevo estado de existencia hombre-computadora (si es que esta asimilación denota un nuevo sentido de conciencia). En la actualidad la investigación se enfoca en este proceso de integración, muchas veces visto en producciones fílmicas de ciencia ficción. Pero este proceso de “antropomorfización de la tecnología” reclama más reflexión. (Van Dijk 1999):

‘In humanizing their relationship with information and communication technologies, humans submit to technology without knowing it’ (pagina 215)⁷

⁷ En el proceso de humanizar nuestra relación con la información y las tecnologías de la comunicación, los humanos nos a la tecnología sin aun conocerla”.

las Tecnologías de la Información

5. A manera de cierre.

La relación Sociedad-Tecnología es compleja, es cada vez más profunda, e increíblemente cotidiana, la Tecnología se inscribe en todos los aspectos de la vida de los sujetos, la interacción es intensa y genera procesos que cambiarán para siempre conceptos básicos como libertad, existencia, ética. Los niños son los que más influencia tendrán a partir de la interacción con los objetos digitales ya que se encuentran en la fase del desarrollo, donde la absorción y modulación desde el exterior es una condición para que se genere el desarrollo. Cada una de las situaciones problemáticas aquí planteadas merece una solución estratégica que sea fruto del debate social.

En la era digital el tiempo se acelera, pero no debemos acelerarnos al momento de reflexionar acerca del proyecto social que está aquí en juego.

6. Cuadro Sinóptico

<i>Aislamiento Social</i>	
Relación con las tecnologías informacionales	Cuando más tiempo se usa un dispositivo tecnológico menos tiempo es el disponible para una interacción "cara a cara con otro ser humano. La comunicación mediada electrónicamente no puede transmitir información periférica y contextual como el tono de la voz los gestos los movimientos de los ojos. Personas con problemas de comunicación podrían encontrar en la comunicación mediada una solución de compromiso. En la actualidad se proponen modelos grupales para el uso de estas tecnologías en el aula con el objeto de prevenir el aislamiento en el salón.
Política Educativa	El aumento en el uso de las tecnologías informacionales en casi todos los aspectos de la vida cotidiana demandan a la educación la inclusión de nociones sobre tecnología. La educación no solo debe servirse de estas tecnologías para actualizarse sino también proveer a los alumnos de formas de análisis del uso de las mismas.
Aspecto legal	Como no es un problema ético directo es dificultoso que la ley pueda regular el uso de estas tecnologías en los niños. Pero si la ley puede dar el marco legal para una reforma educativa que contemple esta situación.
Autorregulaciones	Los niños, en edad de crecimiento desarrollo carecen de la capacidad de autorregulación. Los padres los educadores deberán monitorear la cantidad de horas que los niños consumen frente a los dispositivos electrónicos en comparación con otras actividades donde la interacción cara a cara está asegurada.
Responsabilidad de los diseñadores	Los programas de formación de programadores y diseñadores de las tecnologías informacionales y sus producciones deberán incorporar temas éticos de modo que se puedan resolver, prevenir durante la fase de desarrollo de los productos. Por el otro lado, la comunicación electrónica cuando funciona como una forma más, no como un reemplazo constituye una gran herramienta de comunicación.
Soluciones técnicas	Se puede monitorear la cantidad de horas que una persona consume frente a un dispositivo electrónico. Esto puede ser una herramienta valiosa que ayude a mantener un racional uso de los mismos.
<i>Competencia y violencia</i>	
Relación con las Tecnologías Informacionales	Básicamente se relaciona con los juegos electrónicos, conocidos como plataforma, de guerra o con violencia explícita. Muchos otros juegos que no son electrónicos también son violentos, pero lo relevante aquí es la desaparición de la línea entre realidad y juego dado el realismo de estos programas.
Política Educativa	La violencia en la sociedad no es un emergente de las tecnologías electrónicas, pero si los juegos descriptos pueden reforzar esta tendencia, residuo de la gran competitividad que se vive en la sociedad actual, la educación debe aportar una perspectiva sociológica, más aún multidisciplinaria debe urgentemente ser implementada para comprender esta situación.
Aspecto Legal	Las regulaciones acerca de la edad para acceder a estos juegos parece no ser suficientemente efectiva.
Autorregulaciones	Los adultos encargados de la educación del infante deberían reforzar sus conocimientos acerca de lo que significa el juego en el niño.
La ética de los diseñadores.	Lamentablemente, la ética aquí se contrapone con las demandas del mercado siendo los juegos violentos los más vendidos en los últimos años.
Soluciones técnicas	V-chip. Filtros.
<i>Propiedad Intelectual</i>	
Relación con las tecnologías	A pesar de que las leyes que protegen la propiedad intelectual están desarrolladas, la facilidad con que se puede copiar, distribuir y modificar la información soportada en formatos digitales hacen que el control sea poco

informacionales	posible, las características inmateriales de la información hacen también difícil la reflexión sobre el valor de la misma en los niños.
Política Educativa	La educación se encargara de conceptualizar nuevas formas de creación relacionadas con el tema de la edición, y usabilidad. La información y el conocimiento deben ser repensados.
Aspectos legales	A pesar de que las leyes están redactadas, la postura ética no ha sido lograda a nivel mundial dependiendo del background cultural de cada región. Las leyes del derecho de autor responden también a factores económicos.
Autorregulaciones	Las autorregulaciones deberán centrarse en la valoración de las creaciones intelectuales
Responsabilidad de los diseñadores	Siendo los más dañados económicamente, por esta situación, el dilema parece estar resuelto en este ámbito, aunque existe el espionaje electrónico y los hackers como símbolo de que esto no es tan cierto también.
Soluciones técnicas	Algunos programas tienen programas que impiden su grabación, códigos, mensajes encriptados, etc constituyen herramientas contra este problema
Inteligencia Artificial y toma de decisiones	
Relación con las tecnologías informacionales	Aunque parezca una relación directa se relaciona como el hombre usa estos programas, la tendencia es a reducir la interfaz hombre computadora hasta fundirla en un solo organismo.
Política Educativa	La educación debería introducir teorías sobre el artificial y promover la reflexión profunda acerca de la relación del hombre con estas tecnologías.
Aspecto legal	No hay leyes que se relacionan directamente con esta problemática.
Autorregulaciones	La tendencia de la humanidad a idealizar sus creaciones puede generar una dependencia más allá de lo científicamente cierto respecto de este tipo de programas, lo inesperado queda excluido en estas programaciones basadas en procesos lógicos.
La responsabilidad de los diseñadores	Los diseños de estos programas deberían ser antropocéntricos quedando la decisión del lado del hombre.
Soluciones técnicas	Los programas deberían estar regulados por la toma de decisiones de los humanos. Desde el punto de vista ético, dejando de lado las cualidades eficientes buscadas.

Referencias y bibliografía.

Baase S. *A Gift of Fire*. (1997). USA Prentice-Hall Inc.

Bembenaste, Narciso. "Sujeto= Política*Tecnología/mercado." CBC. 1996.

Dahlbom B., Mathiassen L., 'Power in System Design' in Kling R., ed. (1996) *Computerization and Controversy*, London, Academic Press Limited.

Edge D. 'The Social Shaping of Technology' in Heap N., Thomas R., Einon G., Mason R. and Mackay H., ed. (1995) *Information Technology and Society*, London, Sage.

Ellul Jacques 'The search of ethics in a Technicist Society' in *Research in Philosophy and Technology*, Ferr F, ed. (Greenwich, CT: JAI Press, 1989) page 26. This quotation was extracted from the book: Nardi A., and O'Day B., *Information Ecologies* (1999) USA, MIT.

Ellul Jacques *The Technological Society* (1964) . New York. Vintage.

Eraut M., 'The Information Society – a Challenge for Education Policies? Policies Options and Implementations Strategies' in Eraut ed. *Education and the Information Society*. London, The Council of Europe.

Kallman E., Grillo J. *Ethical Decision Making and Information Society*. (1996) Singapore. Mc Graw-Hill Book Co.

Katz Y., 'Socio-Pedagogical Issues Affecting Computer Assisted Instruction and learning' in Katz Y., Millin D. and Baruch O., ed. (1996) *The impact of Information Technology*. London. Chapman and Hall.

Kling R. 'Ethical issues in the Work of Professionals' in Kling R., ed. (1996) *Computerization and Controversy*, London, Academic Press Limited.

Kling R. 'Information and Computer Scientist as Moral Philosophers and Social Analysts' in Kling R., ed. (1996) *Computerization and Controversy*, London, Academic Press Limited.

Kling R. 'Organizational analyses in Computer Science' in Huff, Ch. And Finholt T., editors (1994) *Social Issues in Computing*, USA, Mc Graw – Hill Inc.

Langford D. *Practical Computer Ethics*. (1995) Maidenhead. Mc Graw-Hill International UK.

Levin R. 'A new look to the patent system' in Huff, Ch. And Finholt T., editors (1994) *Social Issues in Computing*, USA, Mc Graw – Hill Inc.

Lyon D. 'The Roots of the information society idea' in Heap N., Thomas R., Einon G., Mason R. and Mackay H., ed. (1995) *Information Technology and Society*, London, Sage.

Mackay H. 'Theorising the IT/Society Relationship' in Heap N., Thomas R., Einon G., Mason R. and Mackay H., ed. (1995) *Information Technology and Society*, London, Sage.

Markus M. L. 'Finding a Happy Medium: Explaining the Negative Effects Of Electronic Communication on Social Life at Work' in Kling R., ed. (1996) *Computerization and Controversy*, London, Academic Press Limited.

Michie D. 'The social aspects of Artificial Intelligence' in Jones T., ed. (1980) *Microelectronics and Society*. Stratford, The Open University Press.

Naisbitt J. *High Tech High Touch*. (1999) Finland. WSOY.

Shotton M. 'Should Computer Dependency be Consider a Serious Problem?' in Huff, Ch. And Finholt T., editors (1994) *Social Issues in Computing*, USA, Mc Graw – Hill Inc.

Tapscot D., *Growing up Digital*. (1998) USA, Mc Graw-Hill.

Turkle S. 'Hackers: Loving the machines for itself' in Huff, Ch. And Finholt T., editors (1994) *Social Issues in Computing*, USA, Mc Graw – Hill Inc. Copyright 1984 by Sherry Turkle reprinted by permission)

Van Dijk, J. *The Network Society*. (1999) London, Sage.

Virtual Unreality of Videogames

Guardini Pietro[✦]

Department of General Psychology
University of Padova, Italy

ABSTRACT

Beginning with an objection raised to the excessive attention promotion gives to the aspect of "realism" in videogames, I chose to describe instead how excessive realism may be counterproductive. I identify and focus on what game designers wish to obtain from their products, then proceed to introduce and explain the concept of "virtual unreality of videogames". A number of examples and counter-examples serve to describe important principles used by game designers to build what I have called virtual unreality.

Keywords: *videogames, usability, realism, game design, virtual environments*

Received 2 July 2002; received in revised form 14 October 2002; accepted 15 October 2002.

1. Long live realism!

According to the quotes printed on any videogame package found on the shelves of any store, getting as close as possible to reality seems to be their main objective: "If it is possible in the real world, you can also do it here", "Realistic car handling and real damage!", "Artificial Intelligence extremely real!", "Real Race Tracks and Cars", and so on. Be it racing games or sport simulations, the whole videogame industry's objective appears to be the construction of a product as close to reality as possible; after all, "realism" is one of the parameters most widely used by game-magazine journalists to rate videogames, and it is also one of the most commonly-found words in several websites where new or still-in-development titles are advertised. For instance one of the most successful racing games for Sony Playstation is called "*Gran Turismo: the real driving simulator*" (Sony / Polyphony Digital Entertainment,

[✦] Corresponding Author:
Pietro Guardini, Dipartimento di Psicologia Generale,
Università degli Studi di Padova, via Venezia 8, 35131 Padova, Italy.
Tel: +39-049-8276901
Fax: +39-049-8276600
E-mail: pguardini@yahoo.it

1998). It is quite odd that the race for realism is joined even by products inspired in science fiction: for example, space-combat videogames or ones that include characters without any direct reference in the real world, like dinosaurs.

2. How to get closer to reality?

If the word realism applied to videogames is defined as the ability of the videogame to present places, situations and themes that have a clear referent in the real world, and therefore are seen as something that the player / buyer will already be acquainted with, the following question may be asked: how do game designers try to get closer to reality?

3. Graphics & Sound

The first way in which verisimilitude may be obtained is through the graphic aspects: accuracy in the reproduction of objects (such as buildings, vehicles, and characters) is possible on two levels. The first concerns the designing of a model of the represented object ("modelling"), which is constructed by using differently-shaped polygons arranged like building bricks, to occupy a volume in the three-dimensional virtual space. The second concerns textures ("texturing"), that is, images used like wallpaper would be, to coat the outer (and all visible) faces of the model; the photorealistic aspect of three-dimensional objects found in many contemporary products thus depends largely on this element.

In the world of videogames, the modelling process in some cases has required the use of modern and sophisticated technologies, such as Global Position System (GPS) – for instance, to build racing circuits in *F1 Racing Championship* (Ubisoft 2001) – or laser scanning – for car-model construction in *Toca Touring Car Championship* (Codemasters 1997). Through these technologies, a scaled digital clone of the object with extreme precision may be obtained. The texturing process has long been based on the manipulation of actual high-resolution digital photography of the objects to be built. The designer team of the marvellous *Max Payne* (God Games / Remedy 2001), which masterfully tells a story set in New York, revealed they constructed their textures from many pictures taken around the city's different neighbourhoods (Määttä, 2002).

Software houses and publishers spend millions of dollars to secure the official license from FIA (Federation Internationale de l'Automobile) for a Formula 1 videogame, since the license grants them access to the use of the names and faces of actual pilots, as well the appearance of actual championship cars, the logos of sponsors and official racing circuit.

A similar thing applies to the obviously more exclusive world of military and civil flight simulators. In the first case, even the US Air Force was recruited as a collaborator to one product (*U.S. Air Force*, Electronic Arts / Jane's Combat Simulations, 1999), while the second market has virtually been cornered by Microsoft's Flight Simulator (2002, latest version), which sports the logos and sponsorship of impressive firms such as Cessna, Boeing, Bell, and Learjet.

The sound receives no less attention. In car-racing simulators, the noise of engines is usually recorded from real cars, and then reproduced to allow for a wider range and a more accurate characterization of the different types and powers of engines. For example, the presence of the turbo feature in the engine of any car model in the game "*Need for Speed – Porsche 2000*" (Electronic Arts, 2000) may be detected by simply revving the engine – not unlike real life.

4. Dynamics & AI

Once the objects have been built, rules of behaviour are required for the objects if a realistic behaviour is wished. For example, actual physical laws and limitations are resorted to in order to obtain credible movement of any "in game" object, and AI routines have to be inserted to give both motion and motivation to those objects and characters that are outside the player's direct control. For instance, in a football videogame it is to be expected that the ball move as we would see it in a stadium, and that the opposing team does not merely converge on the ball, but organizes to try to steal it away from the human player and score a goal of their own.

5. The point: even better than the real thing

It seems therefore that anyone who buys a videogame will bring home a piece of reality, thus being able to live out experiences that for various reasons may be beyond their reach - a student at the end of the semester will be highly unlikely to be driving a Lamborghini Murciélago along the French Riviera, just as a lawyer with a passion for trains will never be able to pilot the Orient Express, or any more than a retired gardener will be able to enter the skin of Julius Caesar during his Gallic war campaigns...

But this is not the case at all: game developers are well aware of the fact that the final objective towards which they employ their skills has nothing to do with the provision of a duplicate of reality. If this were the case, winning a rally videogame would require the same expertise needed to win a real-life rally. This would mean years of training, dedication and familiarity with the medium, while the videogame player wishes to learn to drive in a few minutes, and to enjoy himself by winning and driving in

spectacular fashion while spending just a few minutes in picking up the relevant skills. A 1:1 relationship between game and reality is not a viable option: a player may win a rally in a videogame even though he may not even have a driving license, because the two things – real-life driving and game-driving – are completely different, and their objectives are different too. The main objective of a videogame is to satisfy a need for entertainment.

The task of any game designer is therefore the construction, within his videogames, of that which I will call "virtual unreality", that is the illusion of a world, a quasi-reality. Its reality is only superficial and apparent, since the videogame world is an artefact, created with the specific goal of fulfilling and even anticipating the expectations of the player at any given moment. Virtual unreality is therefore a less-immediate aspect of the more general concept of virtual reality, bearing in mind that virtual digital worlds are the issue in question.

6. It's not a hardware question

The reasons underlying the difference in objectives adopted in the contextualized settings in videogames (driving a car, playing football, piloting a plane, etc.) are not, as one may think, linked to hardware limitations. The problem does not lie with technical difficulties, such as calculus capacity, the use of specialized hardware to reproduce effects on peripheral control devices (vibrations of the steering wheel due to road conditions, air current that make it more difficult to hold the cloche steady, etc.) or to the player himself (seat vibration, wind in the hair, changes in proprioception).

After all, the availability of peripherals that guarantee a multisensorial feedback has increased constantly: steering wheels, handlebar controllers and joypads with forcefeedback have become the norm after a few years of uncertainty due to high prices and rudimentary technologies. More recent and less widespread products are also available, such as a seat with embedded hydraulic jacks that rotates and inclines, involving the player in its movements, the control peripherals and the computer monitor. The experience is not unlike a ride on a mechanical bull, enhanced by the constant menace that the monitor may become unscrewed from its support thus resulting in multiple facial lacerations – but then again maybe this is just a personal phobia... The "I-smell" technology, which adds to the computer a peripheral that emits different fragrances depending on what the monitor is showing was also the source of much interest, until the lack of funding interrupted any further R&D on the project.

7. Examples

A number of examples supporting the statements that game programmers do not look for a slavish adherence to reality:

Simon Kershaw was the producer of *F-22 Air Dominance Fighter* (Ocean / DID, 1997), by Digital Image Design, a British software house that produced flight simulators both for the military and the home entertainment markets. In an interview he gave in 1997 to the top-selling Italian videogame magazine *The Games Machine* (Silvestri 1997), in answer to the question "Wich are the differences between your flight simulators and videogames?", he admitted that the differences are remarkable, in particular as concerns the behaviour of the plane and the physics of a simulated world. The simulated plane, a modern F-22 fighter, has very efficient computerized systems that would allow the plane to keep its stability even in the event of serious damage to one wing caused by an enemy missile. According to Kershaw, replicating such a device in a videogame would surprise its buyer, since the public paradoxically would not accept it as realistic. Moreover, fights usually occur between planes who are hundreds of miles apart: the enemy is a small dot on a radar, and the range of missiles makes it unnecessary to be close (dogfights, that is, close-up duel between planes, are considered as too dangerous, and the damage caused by short-range weapons, such as a machine gun, is slight if compared to missiles of the "fire and forget" kind). For videogame players, a game structured around the exchange of missiles until the small dot on the radar disappears or the player is eliminated must be highly unappealing, and even more so if he has just watched the movie *Top Gun*, where the planes brush against each other while exchanging machine-gun fire. This is why the programmers have altered the range of missiles, in order to force the planes to draw nearer to their objective before releasing the missiles, a gimmick that makes the fights more challenging.

Also, the stealth devices that make planes invisible to radars in reality would make any game too simple and boring, since the player would be able to easily reach his objective without any counteroffensive, and without any confrontation with enemy planes. According to the development team, this problem has been solved in two different ways. Interactive Magic game designers (*iF-22*, 1997) intervened directly on the plane's capabilities, so that its stealth functions would be less effective; DID programmers left unchanged the plane's parameters, but made it necessary for the plane to exit the stealth mode in order to complete the mission (Silvestri, 1997).

A further example: In his excellent book *Trigger Happy - The Inner Life of Videogames* (2000), Steven Poole mentions the same kind of problem when talking of space-combat simulators, with a particular reference to laser fights. The most common representation of laser cannon consists of two brightly-coloured lines that, once the

trigger has been pulled, converge in one point, where the sight is. The key to victory is shooting through the viewfinder, managing to anticipate the enemy ship.

Already, two mistakes have been made here. Firstly, laser rays in space are not visible, since there is nothing on which the light beam may refract; the depiction of laser rays is therefore incorrect. Secondly, since laser is made of particles that travel at the speed of light, they reach their target almost instantaneously, unlike normal bullets in the Earth's atmosphere, therefore making it unnecessary to anticipate the movements of the enemy. The argument is undeniably persuasive; nonetheless, the decision to prove the thesis of the untrue realism of a videogame that depicts the player as sitting in the pilot's place of a stellar fighter does seem a bit odd.

One last example, also taken from Poole's book: Richard Darling, Creative Director of Codemasters, a British development and production house, in an interview with the author, reveals a device adopted by the game designers of his company to make racing games more fun and challenging: "If you are driving along and you crash, and the pack goes ahead of you, you won't necessarily notice if they all slow down a bit so you get a chance to catch them up, and you feel like you're still in the game – whereas a good player wouldn't have crashed in the first place, and so the cars wouldn't have slowed down, so you can have a competitive time either way" (Poole 2000: p. 186).

8. The exception that proves the rule

Products however do exist that display a high grade of realism and require a remarkable learning curve. The best example is *Grand Prix Legends* (Sierra / Papyrus 1998), which features the Formula 1 World Championship of 1967, including cars that, due to their strict adherence to reality, are particularly hard to handle, due to the power of engines and the lack of adherence to the tarmac of a road. This product required various days of practice in order to complete a few circuit round without accidents, compared to the standard ten minutes or so, and completing a race with a respectable classification may take weeks or even months. *Grand Prix Legends* never became a bestseller, but it does have a hardcore fan basis that has formed online gaming and information-exchange communities, where players may exchange information on the best setup for a certain car and are always ready to challenge each other online. Fans have always developed many add-ons and patches, that is, programmes that may be added to the original videogame, that enhance the use-value of the product introducing new cars, circuits, and details of vehicles and circuits.

9. Building worlds for Virtual Unreality: consistency, supporting design, environmental storytelling.

It is also peculiar that Chris Hecker should begin his article "Physics in computer games" (2000) by citing the very game that we have just been discussing, *Grand Prix Legends*. At the beginning of the he describes the gyroscopic effects of wheels and engine, that are at any moment being calculated in real time in order to influence the oscillations of the car's bodyframe – a testimony to the extent of the programmers' attention to the reproduction of physical behaviour of objects in this game. According to Hecker, videogames "physics simulators" – that is, "the part of the program that controls the physics of the environment, the very rules governing how the entities in the game interact" (p. 35) – have to become increasingly sophisticated to keep up-to-date; therefore, "game developers are turning to serious algorithms from the computer science research community" (p. 35). Being sophisticated however does not completely solve the problem: "the most important question for a game developer to ask is whether the physics simulator in a particular game is a good match for the design" (p. 36) of the game he's working on. Since technical restrictions mean that a family of algorithms that accurately simulate the real world does not exist yet, the game designer is forced to simplify the operation and select an algorithm able to foresee and control only those physical rules that he deems more relevant or indispensable to the functioning of the game.

This is a further example of how a virtual unreality is built, that is, of how game designers do not have the simple task of copying reality, but are forced to build one from scratch, while keeping their objectives present and having to make important choices. And it is precisely these choices who will determine the success of the product.

Hecker himself states that, contrary to what videogame advertising states, "the goal of the games is not reality itself, but the real goal is consistency" (p. 36). A consistent environment requires that the player be immersed into the virtual environment, a concept that in the academic environment is measured as presence. The simplification of physical laws inevitably leads to the appearance of imperfections and inconsistencies in the environment. For example, Richard Rouse III offered an instance set in the roleplaying universe, in which the player must solve a puzzle that requires him to open a door by activating a switch (Rouse, 2001). This is done applying pressure on a plate on the floor under which the device is hidden. To do so, he needs to set a number of objects on the plate, and it so happen that in the next

room he can find a mound of stones. The obvious solution is then to go back and forward between the rooms, carrying and dropping stones until the mechanism is actioned. The game designer has anticipated and inserted this solution in the game. However, the player may also opt for a different solution: dropping his various weapons over the plate, or, through a spell, summon monsters that will position themselves over the plate following the player's order. These are all logical solutions; however, they would only work if the programmer had inserted in the code that the plate may react by opening to objects other than rocks, such as the abovementioned weapons and monsters. If the programmer however has decided that only the weight of stones will open the door, then the player will face one of the inconsistencies of the virtual world ("How is it possible that my whole arsenal is not enough to make the device work?") and will be forced to act in accordance with the will of programmers. This is the anticipatory school of game design, whereby the designer thinks what the player might do and develops (hardwires) the game to function only in accordance with those actions; this school is somehow surpassed by the vision of the complex systems school, of a more holistic nature. For example, if every object in the virtual world is endowed with characteristics that include the attribute "weight", then the player will be able to overcome the pressure-plate puzzle with whatever object he chooses, and will not be limited to the objects selected by the programmer. The development of such a complex system certainly requires greater efforts on the part of game designers, but it is certainly more gratifying both for them and for players to be able to find individual solutions puzzles, thanks to the freedom that the product offers.

This observation leads to important conclusions: the game programmer who resorts to a complex system enables the player to develop a gaming style of his own, and at the same time to avoid the pitfalls of environmental inconsistencies, strengthening the sense of immersion.

It is interesting to note that some of the gaming techniques that may be defined as emergent became very fashionable among players. This was exactly the case with *Quake II* (Activision / idSoftware 1997) and the technique of *rocketjumping*. The aim of this extremely popular first person shooter (FPS) is to get rid of a multitude of enemies by recurring to weapons of different power. Rocketjumping is achieved by picking one of the most powerful weapons (such as the missile launcher), and shooting towards the floor. The result is that the player is propelled upwards, but sustaining in the process a fair amount of self-inflicted damage. The strategy may seem counterproductive at first sight; however, it has been revealed as priceless in deathmatches, that is challenges between two human adversaries: taking a very high leap may enable the player to foil his opponent's attack, or reach strategic positions that would otherwise be

unattainable, from which the player's own attacks may be more successfully carried out. This videogame has evolved and has found a new dimension through the trial-and-error processes carried out by the players themselves, who thus contribute to and welcome the creation of a "virtual unreality".

In the aforementioned example of Quake, the game programmers offer players an avatar with human traits and characteristics, plus power-ups, that is, enhancements of strength, speed, resistance to blows, etc. What would happen if the character that the player controls had utterly different characteristics? This was the case for example with *Alien vs. Predator* and its sequel (Fox Interactive / Rebellion 1999; Sierra / Monolith 2002), games that allow the player to don the gear of an Alien, the selfsame creature that caused so much trouble to Ellen Ripley in the well-known series of films, or of a Predator. The Alien can scale walls like spiders, make huge leaps, have wide-angle vision, and are extremely agile. All these characteristics allows the game player to further engage in what is a clearly fantastic virtual unreality, obviously unlike the real world, but also force him to revise his gaming strategies.

10. Supporting Design

The aseptic and faithful reproduction of the environments that are found in the real world does not therefore seem to be as useful to videogame programming as may seem at first sight. We now may analyze a number of examples of how game designers, making the most of the enormous freedom at their disposal, build virtual environment that spoil the player and comply with his every desire in a hidden way, supporting and guiding him with an invisible hand that masks behind the control type, the environmental design, and the actions of non-playable characters, the evolution of the story arch and the puzzles to be solved. Most of the time, much of the success of a game lies in the ability of the game designer to produce something that avoids being too linear and proceeding along pre-established lines, but also does not give the player full freedom, a characteristic that may result in his feeling disoriented. The player should be able to enjoy "a sense of freedom accompanied by a sense of guidance" (Rouse, 2001). And it is precisely this sense of guidance - constituting part of the essence of the virtual unreality that is the subject of the present article – that is structured through a number of small gimmicks that most of the players will never be aware of, such as the ones that were given as examples. It is almost as though the player signed a contract with the game designers, whereby he will ignore inconsistencies and limits that these will impose on the game. In exchange, the game designer undertakes to create for the player the illusion of an experience that will be highly gratifying.

It is also remarkable to notice how a number of products owe part of their success precisely to the ironic exploitation of this "contract", bringing to the fore to nature of the videogame or purposefully breaking the player's sense of immersion. As example of the further, the intriguing *The Nomad Soul* (Eidos / Quantic Dream 1999), the computer is taken to be a portal to a different real world, where the soul of the player is taken and implanted in the body of a local; the player must then take control of the alien being, and win his own soul back through a number of missions and defeat the enemy. *Metal Gear Solid* (PC-Cdrom version: Microsoft / Konami 2000), a true masterpiece, at one stage of the game pits the player against a character with psychic powers, Psycho Mantis, who is able to anticipate the player's every move and thus avoid all his attack attempts. The player then receives a suggestion: the only way to keep Mantis from reading the direction that the player gives to his character and to have a chance at winning the duel is to unplug his joypad from port one and to insert it into port two. The first example illustrates the ambitious attempt at extending the game to the experience of the player as a whole (if he does not win, he risks losing his soul and having his real-life body controlled by the bad guys from the other dimension). The second constitutes a rather unsettling experience, that jolts the player back to his own world, and forces him, to interact with the hardware interface, precisely the one that ergonomics experts are doomed to disappear, or at least to become as transparent as possible.

Going back to environment design, the claim that the virtual environment is built by game designers to comply with players' requirements and expectations may be easily verified. Real-Time Strategy games (RTS) are based on conquering landscapes: by controlling his forces (characters, vehicles, planes, etc.), and in real time – that is, without having to wait for the opponent's turn –, the player must beat the enemy army deployed in the theatre of operations, the area to be conquered. To achieve conquest, he must destroy the enemy base while protecting his own. The wide availability of the internet and online gaming makes it virtually obligatory for any new game of this kind to be playable in the multiplayer mode, that is against one or more human adversaries linked through the Web. Multiplayer games are played in environment that are built on purpose by game designers. Of the two types of landscape are compared, that is the single- and multiplayer ones, they are revealed as profoundly different, despite their apparent similarities. As Professor Espen Aarseth points out in his analysis of the game *Myth* (Take2 / Bungie 1997): "The single player landscapes are asymmetrical, often linear, with one path through it, and with 'evil' troops placed in ambush along the way". The design of the environment linearizes the options for movements, forcing the

player to follow a predetermined path, usually through a series of important places. "The multiplayer landscapes on the other hand, are symmetrical, open and usually arranged around a central point" (Aarseth 2000).

The single player experience is therefore dominated by the linearity of a storyline, while multiplayer games offer no storyline, merely a neutral environment suitable to all players. In the first case, the environment is part of the challenge, of the difficulties awaiting the player, that go well beyond the presence of the enemy to include impossible-to-cross rivers and well-defended bridges, impenetrable forests and canyons most suited for ambushes. In multiplayer game, the environment is turned into a background and support for the challenge between human players, and must therefore be, at least at the beginning of the game, as neutral as possible to all of them.

This in fact was the case a few years back. However, the AI controlling enemy troops has very rapidly evolved, and today's products only very rarely display "stupid" behaviours on the part of computer-controlled units. The role of game environments therefore changes, and linear landscapes for single-player games are no longer necessary. Their main purpose was hiding the too-simple nature of computer-controlled units, while at present the question lies into the need to create an environment – a game level – that may offer multiple potential chances that both sides – computer- and player-controlled characters – may turn to their advantage. It is certainly not casual that two of the biggest successes of the videogame industry of the past few years have been *Unreal Tournament* (Gt Interactive / Epic Games, 1999) and *Quake III* (Activision / id Software, 1999), which single-handedly introduced an innovative gaming style, developed through the possibilities offered by the Internet. Briefly, these games were designed to be primarily a multiplayer experience, but they also may be used in single-player mode, against very "intelligent" computer-controlled opponents – known as BOTs – that act in levels that are often very articulate while remaining extremely restricted. The player is no longer pitted against the environment, but rather against smarter adversaries in a neutral but resourcefully-designed environment.

11. Environmental storytelling

The design of virtual environments is particularly important in those cases in which the spaces where the player-controlled character acts contribute with a number of elements to the development of the story, thus enriching the player's journey with the infinite details that a book or a movie, due to lack of space and time, would be forced to eliminate. An extraordinary example of this instance is *Half Life* (Sierra / Valve, 1998), a game in which the player controls a technician working in an underground desert testing facility where top secret experiments are carried out on hazardous materials.

Something goes wrong, and after a number of sudden explosions, the player must quickly reach the facility's exit to save himself. In order to do so, he must go through a number of rooms and corridors where he witnesses various events that provide him with clues about what has happened. There are tremors and crumbling walls, flickering neon lights, broken-down doors and the bodies of dead scientists, blood spattered on the walls and, judging by the blood-curdling screams heard, some of them must still be alive, somewhere. All this points to something really serious, and not a mere explosion, having happened: the presence of someone – or something – unknown is felt around the base.

In this instance, the virtual environment is not considered as a background against which the characters move, but plays an active role within the story, as well as being a support for the player's actions.

Don Carson, a freelance designer and conceptual illustrator who for the past 17 years has worked as a designer for many theme parks, including Walt Disney World Florida and Disneyland California, explained this concept with an effective parallelism between theme parks and virtual worlds. According to Carson, both experiences have the same objective: to bring people into the man-made worlds and keep them immersed and entertained. Also, the ways in which this objective is reached are the same: to resort to the narration of a story through the experience of travelling through a real or virtual space, and in particular by giving the visitor (in our case, the videogame player) the chance to choose his path and the actions to take. He uses the term "environmental storytelling" (from theme-park slang), that is, when "the story element is infused into the physical space a guest walk or rides through; (...) in many respects, it is the physical space that does much of the work of conveying the story the designers are trying to tell". The same principle is resorted to *en masse* by successful game designers, together with other gimmicks that Carson splendidly illustrates in his article, "Environmental Storytelling: Creating Immersive 3D Worlds Using Lessons Learned from the Theme Park Industry" (Carson 2000).

12. The Bottom Line

This article began by a definition of the term "realism" as applied to virtual interactive entertainment environments. Realism in videogames does not mean to provide a copy of the physical world, which rather serves as an inspiration and point of departure for the construction of virtual worlds designed to deal with the expectations of its future users, which in turn are based on their own experiences of the physical world. Just as painting and sculpture, the construction of virtual entertainment environments has little to do with the slavish reproduction of reality, being rather subjected to the

perceptive, representative and executive capabilities of human beings. Moreover, it is important to point out that all virtual worlds are built with specific aims in mind (educative, clinical, entertaining, training, etc.), and it is the aim of a programme that serves as its underlying framework.

13. References:

- Aarseth, Espen (2000). Allegories of Space: The Question of Spatiality in Computer Games. In Eskelinen, Markku and Koskimaa Raine (Eds.) *Cybertext Yearbook 2000*, University of Jyväskylä.
- Carson, Don (2000). Environmental Storytelling: Creating Immersive 3d Worlds Using Lessons Learned from the Theme Park Industry. Published online in Gama Network's Gamasutra.com, March 01, 2000. Printable version at:
http://www.gamasutra.com/features/20000301/carson_pfv.htm
- Carson, Don (2000). Environmental Storytelling, Part II: Bringing Theme Park Environment Design Techniques to the Virtual World. Published online in Gama Network's Gamasutra.com, April 07, 2000. Printable version at:
http://www.gamasutra.com/features/20000405/carson_pfv.htm
- Combatsim.com (1997). An Interview with the F22: ADF and TAW Team.
Available at:
Part One: http://www.combatsim.com/archive/htm/htm_arc1/did1.htm,
Part Two: http://www.combatsim.com/archive/htm/htm_arc1/did2_int.htm,
Part Three: http://www.combatsim.com/archive/htm/htm_arc1/did2_int2.htm .
- Combatsim.com (1997). An Interview with Simon Kershaw, Producer for F22 ADF.
Available at: http://www.combatsim.com/archive/htm/htm_arc1/did2.htm .
- Hecker, Chris (2000). Physics in Computer Games. *Communications of the ACM*, July 2000/Vol. 43, No. 7, 35-39.
- Määttä, Aki (2002). Game Developer Conference 2002: Realistic Level Design for *Max Payne*. Published online in Gama Network's Gamasutra.com, May 08, 2002. Printable version at: http://www.gamasutra.com/features/20020508/maatta_pfv.htm
- Norman, Donald (1988). *The Psychology of Everyday Things*. Basic Books, New York.
- Poole, Steven (2000). *Trigger Happy – The Inner Life of Videogames*. Fourth Estate, London.
- Rouse III, Richard (2001). *Game Desing: Theory and Practice*, Chapter Seven: The Elements of Gameplay. Published online in Gama Network's Gamasutra.com, June 27, 2001. Printable version at:

http://www.gamasutra.com/features/20000301/carson_pfv.htm

http://www.gamasutra.com/features/20010627/rouse_pfv.htm

- Silvestri, Stefano (1997). F-22 Air Dominance Fighter: Che la Guerra Abbia Inizio. The Games Machine, 102, 36-41.

14. Games cited:

- *Alien vs. Predator* (Fox Interactive / Rebellion 1999)
- *Alien vs. Predator 2* (Sierra / Monolith 2002)
- *America's Army: Operation* (U.S. Army 2002)
- *F1 Racing Championship* (Ubisoft 2001).
- *F1 Racing Simulation* (Ubisoft 1997)
- *F-22 Air Dominance Fighter* (Ocean / DID, 1997)
- *Gran Turismo* (Sony / Polyphony Digital Entertainment, 1998).
- *Grand Prix Legends* (Sierra / Papyrus 1998)
- *Half Life* (Sierra / Valve, 1998)
- *iF-22* (Interactive Magic, 1997)
- *Max Payne* (God Games / Remedy 2001)
- *Metal Gear Solid* (PC-Cdrom version: Microsoft / Konami 2000)
- *Microsoft's Flight Simulator* (Microsoft, 2002: latest version)
- *Monaco Grand Prix Racing Simulation 2* (Ubisoft 1998)
- *Myth* (Take2 / Bungie 1997)
- *Need for Speed – Porsche 2000* (Electronic Arts, 2000)
- *Quake II* (Activision / idSoftware 1997)
- *Quake III* (Activision / id Software, 1999)
- *The Nomad Soul* (Eidos / Quantic Dream 1999)
- *Toca Touring Car Championship* (Codemasters 1997)
- *U.S. Air Force* (Electronic Arts / Jane's Combat Simulations, 1999)
- *Unreal Tournament* (Gt Interactive / Epic Games, 1999)